

Coinage Metal–*N*-Heterocyclic Carbene Complexes

Joseph C. Y. Lin, Roy T. W. Huang, Chen S. Lee, Amitabha Bhattacharyya, Wen S. Hwang, and Ivan J. B. Lin*

Department of Chemistry, National Dong Hwa University, Hualien 974, Taiwan

Received November 10, 2008

Contents

1. Introduction	3561
2. Ag(I)–NHCs	3563
2.1. Historical Background	3563
2.2. General Synthetic Methods	3563
2.3. Formation of Ag(I)–NHCs	3563
2.3.1. Mono-NHC Ligands	3563
2.3.2. Zwitterionic Mono-NHC Ligands	3566
2.3.3. Chiral Mono-NHC Ligands	3566
2.3.4. Mono-NHC Ligands with P- and N-Donor Side Arms	3567
2.3.5. Multi-NHCs Linked by Spacers	3568
2.4. The Ag ₂ O Route	3570
2.4.1. Feasibility	3570
2.4.2. Complications	3571
2.4.3. Theoretical Consideration	3572
2.5. Applications	3572
2.5.1. Ag(I)–NHCs in NHC Transfer	3572
2.5.2. Ag(I)–NHCs in Catalysis	3572
2.5.3. Ag(I)–NHCs in Medicine	3572
2.5.4. Ag(I)–NHCs in Nanomaterials	3573
3. Au(I)– and Au(III)–NHCs	3573
3.1. Historical Background	3573
3.2. General Synthetic Methods	3573
3.3. Formation of Au(I)– and Au(III)–NHCs	3574
3.3.1. Neutral [Au(NHC)L]	3574
3.3.2. Ionic [Au(NHC)L][Anion]	3576
3.3.3. Multinuclear Au(I)–NHCs	3578
3.3.4. Other Classes of Au(I)–NHCs	3578
3.3.5. Au(III)–NHC Complexes	3579
3.4. Applications	3579
3.4.1. Au(I)– and Au(III)–NHCs in Catalysis	3579
3.4.2. Au(I)–NHCs in Medicine	3580
4. Cu(I)– and Cu(II)–NHCs	3581
4.1. Historical Background	3581
4.2. General Synthetic Methods	3582
4.3. Formation of Cu(I)– and Cu(II)–NHCs	3583
4.3.1. Complexes Containing the Cu(NHC) ₂ Core	3583
4.3.2. [Cu(NHC)(Halide)]	3583
4.3.3. [Cu(NHC)(Ligand)]	3584
4.3.4. Multinuclear Cu(I)– and Cu(II)–NHCs	3589
4.4. Catalysis	3591
4.4.1. Past Events	3591
4.4.2. Recent Advancements	3591

5. Photoluminescence	3592
6. Conclusions	3594
7. Abbreviations	3594
8. Acknowledgments	3595
9. References	3595

1. Introduction

An *N*-heterocyclic carbene (NHC) contains a carbene carbon incorporated in a nitrogen-containing heterocycle, presumably reactive and difficult to isolate.¹ The first isolation of free NHC dates back to 1991.² Many advances have since been made on the synthesis, characterization, and reactions of NHCs with diverse electronic and steric properties.^{3–5} Many NHCs are now commercially available. The chemistry of NHCs has become mainstream in organometallics, rivaling the ubiquitous tertiary phosphines.^{1,6–8} Due to their good σ -donating property, NHCs could form stronger bonds with most metals compared with phosphines.⁷ The electron richness of NHCs may influence various reactions, such as oxidative addition.^{1,9} Indeed, metal–NHC complexes prove to be more effective in many catalytic reactions than metal–phosphine complexes.^{10–12}

Coinage metal–NHCs are widely studied for their intriguing structural properties and numerous applications. Ag(I)–NHCs have become the most studied among coinage metal–NHCs due to their easy preparation via the Ag₂O route and because they are sources of other metal–NHCs through transmetalation.¹³ In addition, their diverse properties in bonding and structure and potential applications in medicine,¹⁴ nanomaterials,^{12,14a,15} liquid crystals,¹⁵ and organic catalysis^{14a} also contribute to the attraction of Ag(I)–NHCs. Since the last review in 2007,¹⁶ more than 100 articles concerning Ag(I)–NHCs have appeared. In this review, the recent Ag(I)–NHC works are covered.

The interest toward Au(I)– and Au(III)–NHCs has surged in the past decade because of easy preparation via the Ag carbene transfer route and the varieties in properties and applications. Gold compounds, long despised for low catalytic activity, have suddenly attracted the attention of organometallic chemists.^{17,18} Many new Au(I)/(III)-catalyzed reactions were recently devised;¹⁹ some among them made use of Au(I)– and Au(III)–NHCs.^{18,20} Au(I)–NHCs have shown potential for applications in medicine, especially in anticancer,²¹ antiarthritis,²² and antibacterial activities.²³ Auophilicity,²⁴ with magnitude similar to hydrogen bonding, provides additional stability to gold superstructures and sometimes constitutes intriguing luminescence properties.²⁵ The latter in particular gives rise to potential applications in sensors²⁶ and medical probing.²⁷ Since our 2005 review, over 70 new articles have appeared,²⁸ including a general review

* E-mail: ijblin@mail.ndhu.edu.tw.



Joseph Chiao-Yang Lin was born in 1979 in Kaohsiung. He received his B.S. degree in Chemistry in 2002 and M.S. degree in 2005 from National Dong-Hwa University. His M.S. was under the supervision of Prof. Thomas Y. R. Tsai. He is now a Ph.D. student in the research group of Prof. Ivan J. B. Lin. His research focuses on nanocatalysis and the synthesis of functionalized imidazolium salts.



Amitabha Bhattacharyya received his Ph.D. from the Raman Research Institute, Bangalore, India, in 1999. He was a postdoctoral fellow at the Laboratoire de Physique des Solides, Orsay, France, from 1999 to 2001, then again at Institut Francais du Pétrole, Rueil-Malmaison, France, from 2001 to 2002. He joined St Joseph's College, Darjeeling, India, as Lecturer in Physics in 2003. He is presently a postdoctoral fellow under Prof. Ivan J. B. Lin, on leave from his position in India. His research interests are liquid crystals, surfactants, and Langmuir and Gibb's monolayers.



Roy Tsung-Wen Huang was born in 1978 in Taipei. He received his B.S. (2001) in chemistry from Chinese Culture University and M.S. degree (2005) from Fu Jen Catholic University. He is now a Ph.D. student in the research group of Prof. Ivan J. B. Lin. His research focuses on liquid crystals and functionalized metal-carbene complexes.



Wen-Shu Hwang received his B.S. in chemistry from Tamkang University (1972) and Ph.D. in 1979 at Oregon State University while working with Prof. J. P. Yoke. After organometallic chemistry postdoctoral work with Prof. J. K. Kochi at Indiana University, he joined the faculty at the National Sun Yat-sen University in 1980 as associate professor. In 1994, he moved to National Dong-Hwa University as professor, where he now holds the position of President of the University. His research interests are in metal complexes of thiophene containing Schiff bases including their reactions, structure, and electrochemical behavior. Other research activities include the design of catalysis, photochemistry, and molecular cages by using metal-*N*-heterocyclic carbene complexes.

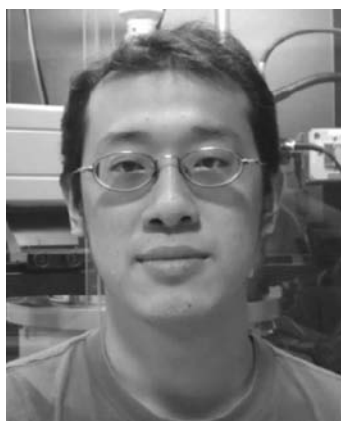

Chen-Shiang Lee was born in Taiwan in 1981. He began studying Chemistry in 1999 as an undergraduate and got his B.S. from the National Dong-Hwa University. He joined the research team of Prof. Wen-Shu Hwang in 2004 and is currently a Ph.D. candidate in chemistry. His research includes metal-*N*-heterocyclic carbene complexes, catalysis, and photoluminescence.

plexes.³⁰ In this review, we will cover Au(I)- and Au(III)-NHC works published since 2005.

Despite being the least stable among the coinage metal-NHC complexes, investigations on Cu(I)- and Cu(II)-NHCs have increased substantially. This is mainly due to their potential as catalysts in many organic transformations.³⁰ Copper catalysts with a tunable NHC ligand enable improved reactivity and reaction selectivity. Cu(I)-NHCs may also find industrial applications, such as in CO₂ to CO reduction and hydrogen storage.³⁰ In more than 80 studies published since 1993, relatively few well-characterized Cu(I)- and Cu(II)-NHC complexes have been reported.

Theoretical studies have shed light into the fundamental issues concerning the stability of free NHCs and the metal-NHC bond.³¹⁻³⁴ The dissociation energies predicted at the CCSD(T) level of theory indicate strong coinage

on Au(I)- and Au(III)-carbene complexes²⁹ and a review on catalytic application of Au(I)- and Au(III)-NHC com-



Ivan J. B. Lin received his B.S. degree (1969) in chemistry from Tamkang University and Ph.D. degree (1975) under the supervision of Prof. John P. Fackler, Jr., at Case Western Reserve University, Cleveland, Ohio, in 1975. After postdoctoral studies with Prof. G. W. Everett, Jr., at Kansas University in 1976; he moved to the University of New Brunswick in Canada with Prof. F. Bottomley in the same year. In 1980, he returned to Fu Jen Catholic University in Taiwan as an associate professor and then professor in 1983. He spent a year at Ottawa University in Canada as a visiting scientist with Prof. H. Alper in 1986. Then he continued his service at Fu Jen Catholic University until 2002. Currently he works at National Dong-Hwa University as Dean of the college of science and engineering. His research interests are liquid crystals, *N*-heterocyclic carbene complexes, nanomaterials, lithium battery electrolytes, and emissive metal–organic compounds.

metal–NHC bonds with a trend of Au > Cu > Ag.³² Density functional theory (DFT) calculations show that the metal–NHC bonds are dominantly electrostatic in nature with minor covalent interactions, the covalent interaction being largely σ -bonding.³³ DFT calculations also suggest that NHCs are stronger σ -donors and weaker π -acceptors than the phosphine ligands.³⁴ Finally, DFT calculations have been performed to understand the reaction of imidazolium iodide with Ag₂O in CH₂Cl₂.³⁵ A reaction mechanism, which is thermodynamically driven and takes place at low activation energies, has been proposed.

In this review, we attempt to provide an overview of the chemistry and physics of coinage metal–NHCs. The sections are organized in the order Ag, Au, and Cu; the compounds designated with **I**, **II**, and **III** represent silver, gold, and copper, respectively. Each section begins with a brief historical background, a summary of the various synthetic methods, a description of recent progress on compound formations and properties, and subsequently, a discussion

Scheme 1

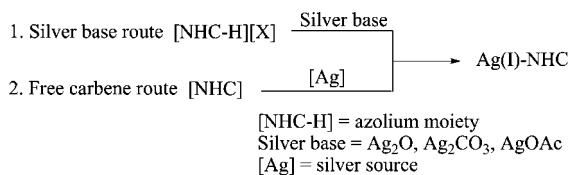

Scheme 2

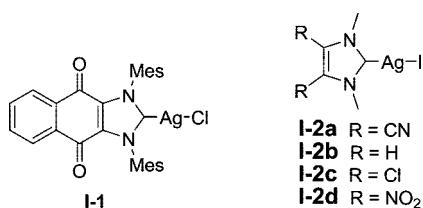

on applications. The chemical shifts (δ) of the carbenic carbon in the ¹³C NMR (¹³C_{NHC}) are tabulated in Tables 1, 2, and 3. A section on photoluminescence for the Ag- and Au-NHC complexes is provided. We also tabulate the details pertaining to the luminescent properties in Tables 4 and 5. The definitions of the abbreviated organic functional groups used in this review are tabulated in section 7, Abbreviations, at the end of the article.

2. Ag(I)–NHCs

2.1. Historical Background

The first well-characterized Ag(I)–NHC complex was synthesized by Arduengo's group in 1993, utilizing free NHC and silver salt.³⁶ In 1997, Bertrand and co-workers first used silver acetate as a silver base to react with dicationic 1,2,4-trisubstituted triazolium salts to synthesize unstable polymeric Ag(I)–NHCs in refluxing THF.³⁷ In the next year, Lin's group reported the facile formation of Ag(I)–NHCs¹³ by employing Ag₂O to react with benzimidazolium salt in CH₂Cl₂ under ambient conditions by a serendipitous discovery.³⁸ Several reviews on Ag(I)–NHCs appeared in the past few years. Arnold wrote a minireview partially on Ag(I)–NHCs in 2002.³⁹ Lin's group has reviewed Ag(I)–NHCs in 2004⁴⁰ and 2007.¹⁶ Youngs' group summarized the synthesis, structure, and applications of Ag(I)–NHCs in 2005^{14a} and also published a minireview on Ag(I)–NHCs as a new class of antibiotics in 2007.^{14b}

2.2. General Synthetic Methods

Since our last review,¹⁶ the methods used to access Ag(I)–NHCs can be categorized into (1) the silver base technique and (2) the free carbene method, shown in Scheme 1. The free carbene method, although popular for the synthesis of many metal–NHC complexes, is very sparingly used in Ag(I)–NHC synthesis. This may be attributed to the simplicity of the silver base route, especially using Ag₂O as a base and Ag source. Unless otherwise stated, the Ag(I)–NHC complexes mentioned hereafter are synthesized by the Ag₂O silver base route.

2.3. Formation of Ag(I)–NHCs

In this section, the formation of Ag(I)–NHCs has been classified by the types of NHCs. Chemical and physical properties of the Ag(I)–NHCs are also discussed here. The ¹³C_{NHC} δ values for these complexes, ranging between 160 and 220 ppm, are given in Table 1.

2.3.1. Mono-NHC Ligands

Scheme 2 indicates the Ag(I) complexes with quinone-annulated NHC **I-1**^{41a} and 4,5-disubstituted NHCs **I-2**⁴² designed and synthesized to explore the nature of π -bonding interactions of the Ag(I)–NHC bonds. Infrared (IR) stretching frequencies of the C=O group in **I-1** and the C \equiv N group in **I-2** were used to monitor their bonding interactions. Both frequencies observed were lower than those in the corresponding imidazolium salts, a result attributed to the π -back-bonding of the NHCs in the Ag(I)–carbene bonds. **I-1** has also been utilized as NHC transfer agent in the synthesis of Rh(I)–NHC; a similar trend in ν (C=O) stretching vibration has been observed. Results of ¹³C NMR also support the π -back-bonding interactions of the Ag(I)–carbene bonds.

Table 1. $^{13}\text{C}_{\text{NHC}}$ δ Values (Coupling $^1J(^{107}\text{Ag}, ^{109}\text{Ag})$ or $^1J(^{107}/^{109}\text{Ag})$) for $\text{Ag(I)}\text{-NHC}$ Complexes

compd	δ , ppm (J , Hz)	compd	δ , ppm (J , Hz)
I-1 ^{41a}	193.0 ^d	I-39c ⁷⁶	182.1 ^c
I-2a ⁴²	192.7 ^b	I-39d ⁷⁶	179.0 ^c
I-2d ⁴²	188.2 ^b	I-40a ⁷⁶	174.0 ^c
I-3 ⁴³	177.0 ^c	I-40b ⁷⁶	171.0 ^c
I-4 ⁴³	182.8 ^c	I-41b ⁷⁷	181.5 ^c (238.0, 271.0)
I-5a ⁴⁴	181.6 ^c	I-41c ⁷⁷	181.4 ^c (236.0, 274.0)
I-5b ⁴⁵	181.4 ^c	I-41d ⁷⁷	181.9 ^c (237.0, 272.0)
I-6 ⁴⁵	185.4 ^c	I-41f ⁷⁷	182.0 ^c
I-7 ⁴⁵	179.7 ^c	I-43 ⁷⁹	184.1 ^c
I-8 ⁴⁶	178.3 ^c	I-44 ⁸⁰	170.4 ^c
I-9 ⁴⁷	183.9 ^c	I-46 ⁸¹	234.0 ^c (232.7, 268.4)
I-10a ⁴⁸	179.7 ^c	I-47a ^{82a}	205.6 ^c (182.5, 186.8)
I-10b ⁴⁸	178.7 ^c	I-47b ^{82b}	206.5 ^c (185.5)
I-11a ⁴⁸	175.1 ^c	I-48a ⁸³	194.2 ^d
I-11b ⁴⁸	173.8 ^c	I-48c ⁸³	190.5 ^b
I-12 ⁴⁹	181.7 ^c	I-49 ⁸⁴	182.0 ^b
I-14a ⁵²	180.5 ^b	I-50a ^{85a}	184.7 ^c
I-14b ⁵²	180.4 ^b	I-50b ^{85b}	183.5 ^c
I-14c ⁵²	180.2 ^b	I-51 ⁸⁶	180.1 ^b
I-14d ⁵²	181.2 ^b	I-52b ⁸⁷	180.0 ^c
I-14e ⁵²	181.6 ^b	I-52c ⁸⁷	178.8 ^c
I-16 ⁵⁵	151.2 ^c	I-52d ⁸⁷	182.3 ^c
I-17 ⁵⁵	183.0 ^c	I-53a ⁸⁸	184.9 ^c
I-18 ⁵⁵	182.1 ^c	I-53b ⁸⁸	180.0 ^c (185.4)
I-19 ²³	166.9 ^c	I-56 ⁸⁹	182.5 ^b
I-20a ^{14c}	178.6 ^b	I-57 ⁸⁹	180.2 ^b
I-20b ^{14c}	179.7 ^b	I-58 ⁹⁰	184.6 ^b
I-20c ^{14c}	182.0 ^b	I-60a ⁹²	182.6 ^c
I-21a ⁵⁸	171.2 ^c	I-60b ⁹²	180.8 ^c
I-21b ⁵⁸	172.2 ^c (195.0)	I-60c ⁹²	179.6 ^c
I-23 ⁶⁰	206.0 ^c (223.0, 255.0)	I-60d ⁹²	180.2 ^c
I-24 ⁶⁰	205.5 ^c (221.9, 255.4)	I-61 ⁹²	183.9 ^c
I-25 ⁶²	209.7 ^c (234.0, 270.0)	I-63a ⁹⁵	157.0 ^c
I-26b ⁶³	207.0 ^{c,e} (167.0, 193.0 ^e)	I-67 ⁹⁹	178.0 ^b (186.5, 215.5)
I-26d ⁶³	206.4 ^c (224.0, 259.0)	I-69 ¹⁰⁰	170.0 ^b
I-26e ⁶³	218.6 ^{c,e} (174.0, 201.0 ^e)	I-70 ¹⁰⁰	174.0 ^b
I-26g ⁶³	210.1 ^{c,e} (179.0, 206.0 ^e)	I-72a ¹⁰²	188.27 ^a
I-26h ⁶³	218.6 ^c (226.0, 262.0)	I-73 ¹⁰³	181.9 ^b
I-31a ⁶⁷	172.5 ^b	I-74 ¹⁰³	181.3 ^b
I-31b ⁶⁷	174.0 ^b	I-75a ¹⁰⁴	180.5 ^b
I-32 ⁶⁸	186.5 ^b	I-75b ¹⁰⁴	180.6 ^b
I-33a ⁶⁹	193.2 ^d (234.9, 271.0)	I-76 ¹⁰⁵	181.9 ^b
I-33b ⁷⁰	192.1 ^c	I-77 ¹⁰⁶	189.3 ^b (189.0)
I-34a ⁷¹	192.15 ^d (189.4, 218.8)	I-79a ¹⁰⁹	178.2 ^b
I-34b ⁷¹	193.94 ^d (190.5, 219.7)	I-79c ¹¹⁰	180.5 ^b
I-35a ⁷²	182.0 ^g	I-79d ¹¹¹	177.6 ^f (233.4, 269.1)
I-35b ⁷²	180.6 ^g (180.3, 207.6)	I-80 ¹¹⁰	184.4 ^b
I-35c ⁷²	182.7 ^b (193.9)	I-81 ¹¹¹	180.0 ^f (180.8, 209.5)
I-35d ⁷²	180.8 ^b (181.6, 209.5)	I-82 ¹¹²	181.9 ^b
I-35e ⁷²	180.7 ^b (182.4, 210.8)	I-83 ¹¹²	190.3 ^b
I-36 ⁷³	199.4 ^c	I-84 ¹¹³	180.3 ^b
I-37 ⁷⁴	179.6 ^c (270)	I-86 ¹¹³	179.6 ^b
I-39a ⁷⁵	180.9 ^c		

^a C_6D_6 . ^b $\text{DMSO}-d_6$. ^c CDCl_3 . ^d CD_2Cl_2 . ^e Dimeric isomer ($[\text{Ag}(\text{NHC})_2][\text{AgBr}_2]$). ^f Acetone- d_6 . ^g D_2O . ^h CD_3CN .

The chemical shifts of the complexes **I-1** (193.0 ppm), **I-2a** (192.7 ppm), and **I-2d** (188.2 ppm) are comparable to those of electron-withdrawing naphtha-^{41b} (197.5 ppm) and quinoxaline-annulated^{41c} (197.4 ppm) $\text{Ag(I)}\text{-NHC}$ s, described in our previous review.¹⁶

Complexes **I-3**–**I-15** are sketched in Scheme 3. In an effort to continue searching for $\text{Ag(I)}\text{-NHC}$ s capable of catalyzing ring-opening polymerization (ROP) of L-lactide, complexes **I-3** and **I-4** were synthesized.⁴³ Low molecular weight polylactide polymers having narrow molecular weight distributions were obtained. $\text{Ag(I)}\text{-NHC}$ complexes **I-5a**⁴⁴ and **I-5b**–**I-7**⁴⁵ have also been synthesized as NHC transfer agents to generate the corresponding $\text{Au(I)}\text{-NHC}$ s. Complex **I-8** was prepared to act as a precursor in the formation of

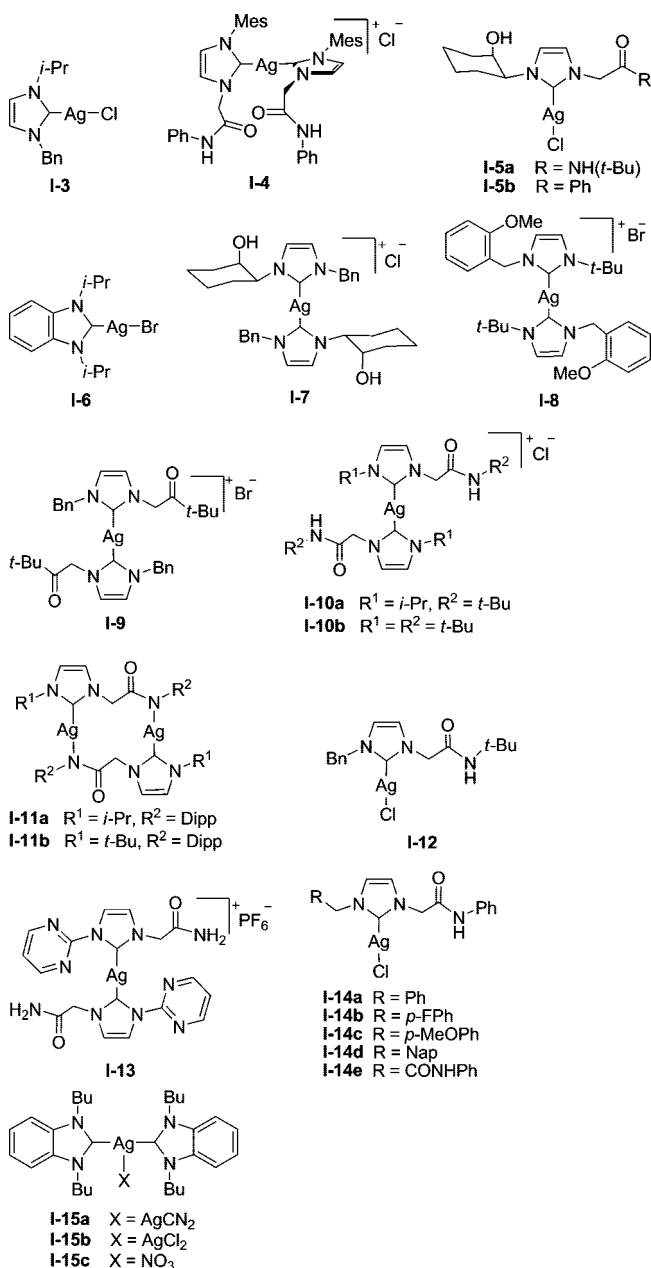
Scheme 3

Au(I) – and Pd(II) – NHC complexes for Suzuki-coupling reactions.⁴⁶ Similarly, carbonyl-functionalized complex **I-9** was employed to prepare Pd(II) – NHC s for Sonogashira cross-coupling reactions.⁴⁷ The same research group also developed several N -amido-functionalized $\text{Ag(I)}\text{-NHC}$ complexes. A mere change at the amido- N substituent can change the reaction products. For a t -butyl substituent, the carbenic proton is deprotonated to form cationic NHC **I-10**.⁴⁸ For a Dipp substituent, both the carbenic and the amido protons are deprotonated to form a 12-membered macrometallo-cyclic compound **I-11**. Conformational isomers are found for **I-11** in the solid state. While **I-11a** adopts a chair conformation, **I-11b** is found in both chair and boat conformations. The amido-functionalized $\text{Ag(I)}\text{-NHC}$ complex **I-12** assembles through a $\text{Ag}\cdots\text{Ag}$ contact (ca. 3.197 Å) to form a dimer.⁴⁹ Complexes **I-10**–**I-12** are all luminous.

Recently, manipulation of crystal packing topology of $[\text{M}(\text{NHC})_2]^+$ type complexes through complexation with N -amido- N' -pyrimidyl-substituted NHC s has been investi-

Scheme 4

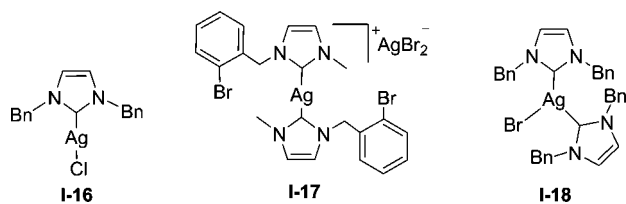

Scheme 5

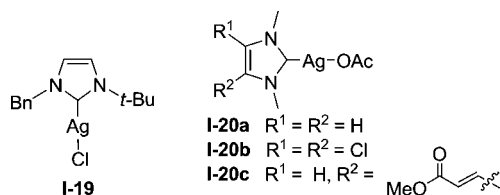

gated.⁵⁰ Ag(I)–NHC complex **I-13** adopts a *trans* conformation, whereas the analogous Hg(II)–NHC adopts a *cis* arrangement. Amido hydrogen bonding motifs are well-known supramolecular synthons in crystal engineering.⁵¹ The *trans* **I-13** assembles to form a 2-D layer structure through hydrogen bonding interactions between the intermolecular amides, while the *cis* conformation of the Hg(II)–NHCs forms a rectangular column architecture. *N*-Amido-functionalized compounds **I-14** have an infinite 1-D staircase motif via bridging Cl⋯H bonding interactions.⁵² Reacting *N,N'*-dibutyl-imidazolium iodide with Ag₂O produced unexpected results.⁵³ Rather than the expected complex with AgI₂[−] anion, **I-15a** with Ag(CN)₂[−] anion was produced in acetonitrile and **I-15b** with AgCl₂[−] in CH₂Cl₂. When the reaction was carried out in THF with an additional 0.5 equiv of AgNO₃, **I-15c** with NO₃[−] anion was formed. The reaction of Ag₂O with imidazolium iodide in CH₂Cl₂ to give AgCl₂[−] anion instead of the expected AgI₂[−] anion has been reported by others.⁵⁴

Scheme 4 lists three Ag(I)–NHC complexes **I-16**–**I-18** with *N*-benzyl substituents.⁵⁵ Compound **I-18** has a three-coordinated Ag(I) center with two NHCs and a bromide ligand in a planar geometry, a coordination mode uncommon in the chemistry of Ag(I)–NHCs. Recently, complex **I-16** has been used to prepare a Rh(I)–NHC complex.⁵⁶

Scheme 5 shows some Ag(I)–NHCs prepared to study their potential in medicinal applications.^{14b,c,23,57} Complex **I-19** was synthesized by the Ag₂O method and used to prepare a Au(I)– and a Pd(II)–NHC complex.²³ These three metal–NHC complexes were studied for antimicrobial activities. Compounds **I-20** of the type [Ag(NHC)(OAc)] were synthesized using silver acetate as the silver base. Their anticancer and antimicrobial activities were studied.^{14c} While the synthesis of compound **I-20a** required 40 h under refluxing conditions, **I-20b** and **I-20c** with electron-withdrawing groups at the NHC backbone could be prepared in a few hours at room temperature. This is an indication that the reactions are p*K*_a dependent.

[Ag(NHC)₂][BF₄][−] type complexes **I-21**, in which the C^{4/5} positions of the NHCs were substituted with methyl groups, were synthesized via the free carbene route (Scheme 6).⁵⁸ They are stable solids in dry air but slowly decompose in solution. The decomposition rate depends on the *N*-substituents, as monitored by ¹H NMR spectroscopy. **I-21a** with an *N*-ethyl group decomposed completely within a few hours, whereas **I-21b** with an *N*-isopropyl group could last for a week. An *N*-neopentyl group could also stabilize the Ag(I)–NHC complex, even without the backbone substitu-

Scheme 6

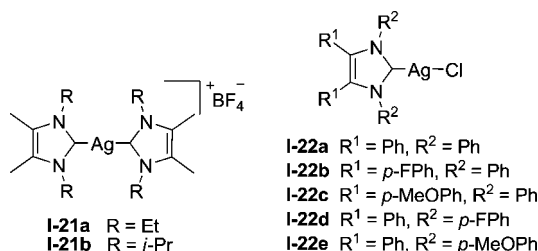

Scheme 7

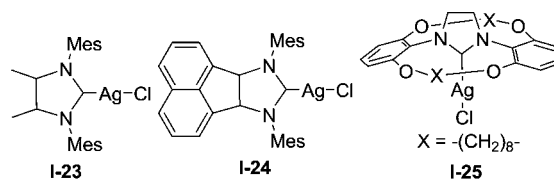

Compd	R	n
I-26a^c	Xyl	0
I-26b^b	Mes	
I-26c^a	Dipp	
I-26d^a	Xyl	1
I-26e^b	Mes	
I-26f^a	Dipp	
I-26g^c	Xyl	2
I-26h^a	Mes	
I-26i^a	Dipp	

Compd	R
I-27a^c	Xyl
I-27b^a	Mes
I-27c^a	Dipp

^aneutral; ^bionic; ^cneutral/ionic

^aneutral; ^bionic; ^cneutral/ionic

tion at the NHC.^{41c} The complexes **I-21** failed in the formation of Re(V)–NHCs. The Ag(I)–NHC complexes **I-22** were synthesized via the Ag₂O route.⁵⁹ The corresponding precursor 1,3,4,5-substituted tetra-arylimidazolium chlorides were prepared through cyclization of aldimine with formaldehyde.

Scheme 7 lists complexes **I-23**–**I-27**, among which complexes **I-23**–**I-26** have a saturated backbone at the NHC, whereas complexes **I-27** have a benzannulation at the 5,6-position of a nonaromatic NHC.^{60–63} Compounds **I-23** and **I-24** were used as carbene precursors to synthesize thiones and Pd(II)– and Rh(I)–NHC complexes.⁶⁰ The Pd(II)–NHC complex was used as a catalyst for a Suzuki-coupling reaction.⁶¹ Bimacrocyclic Ag(I)–NHC complex **I-25** with imidazolidin-2-ylidene was utilized to produce Cu(I)–, Rh(I)–, and Ir(I)–NHC complexes.⁶² The Cu(I)–NHC was used in catalyzing cyclopropanation of olefins with ethyl diazoacetate. The scope of the Ag₂O technique has been extended to six- and seven-membered NHCs, as marked by the synthesis of complexes **I-26** with saturated five-, six-, and seven-membered NHCs and **I-27** with benzo-diazepanyl NHCs.⁶³ Some free carbenes have been isolated in the form of stable white solids and studied by single-crystal X-ray diffraction (XRD). Seven-membered Ag(I)–NHC complexes gave downfield ¹³C_{NHC} δ values of 214–218 ppm compared with 204–207 ppm for the corresponding five- and six-membered counterparts. This would suggest less effective

Scheme 8

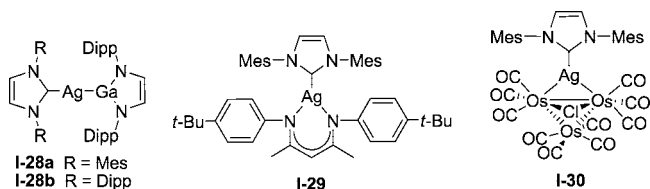

electron donation from N atoms to the carbene carbon in the seven-membered ring and hence a higher triplet contribution to the electronic structure of the carbenes.⁶³

Complexes **I-26** and **I-27** exist as neutral $[\text{Ag}(\text{NHC})\text{Br}]$ or ionic $[\text{Ag}(\text{NHC})_2][\text{AgBr}_2]$ species or both in solution.⁶³ Relative to the ionic complexes, the neutral complexes have $^{107/109}\text{Ag}-^{13}\text{C}_{\text{NHC}}$ coupling constant higher by 55–60 Hz and a lower ^1H NMR shift of the methyl groups by 0.5 ppm. This is also supported by the $^{13}\text{C}_{\text{NHC}}$ data of an analogous seven-membered ionic complex with the BF_4 anion. These features were utilized in determination of the type of the species. Only the *N*-mesityl-substituted **I-26b** and **I-26e** complexes are exclusively ionic. The *N*-xylyl-substituted compounds **I-26a**, **I-26g**, and **I-27a** exist as mixtures of the ionic and neutral forms in various proportions. All the other complexes are neutral. Attempts to synthesize $\text{Pd}(\text{II})-$, $\text{Rh}(\text{I})-$, and $\text{Ir}(\text{I})-\text{NHC}$ complexes using these $\text{Ag}(\text{I})-\text{NHC}$ s as transfer agents failed.

$\text{Ag}(\text{I})-\text{NHC}$ complexes with an anionic heterocyclic ligand, chelating ligands, or cluster ligands coordinated to Ag are compiled in Scheme 8. Complexes **I-28** were synthesized by the reaction of an anionic Ga(I)-heterocyclic ligand with $[\text{Ag}(\text{NHC})\text{Cl}]$ type complexes in THF.⁶⁴ A three-coordinated compound, **I-29**, was prepared by a reaction between $[\text{Ag}(\text{NHC})\text{Cl}]$ and a bidentate β -diketiminato ligand in CH_2Cl_2 at 0 °C.⁶⁵ Unexpected results were obtained on attempting to synthesize Os–NHC complexes from the $\text{Ag}(\text{I})-\text{NHC}$ s. Reaction of *N*-mesityl-substituted $[\text{Ag}(\text{NHC})\text{Cl}]$ with $[\text{Os}_3(\text{CO})_{10}(\text{CH}_3\text{CN})_2]$ produces a heterobimetallic complex $[\text{Os}_3(\mu\text{-Cl})(\text{CO})_{10}(\mu\text{-Ag}(\text{NHC}))]$, **I-30**, along with a side-product composed of an imidazolium cation and an $[(\text{Os}_3(\mu\text{-Cl})(\text{CO})_{10})_2(\text{NCCH}_3)_2\text{Ag}]$ anion.⁶⁶ Facile insertion of the Os cluster into the Ag–Cl bond occurred, leading to the formation of **I-30**, indicating a failure of the Ag–carbene transfer route. On the other hand, the reaction of $[\text{Ag}(\text{NHC})\text{Cl}]$ with $[\text{Os}_3(\mu\text{-H})_2(\text{CO})_{10}]$ provided $[\text{Os}_3(\mu\text{-H})(\mu\text{-Cl})(\text{CO})_9(\text{NHC})]$, in which both NHC and Cl were transferred.

Scheme 9 shows several $\text{Ag}(\text{I})-\text{NHC}$ complexes with benz/pyrido-imidazol-2-ylidenes. Silver chloride bridged dinuclear $\text{Ag}(\text{I})-\text{NHC}$ complexes **I-31** were obtained from the NHC precursor *N*-alkyl-*N'*- CH_2Ant -benzimidazolium salt.⁶⁷ They showed intermolecular $\pi-\pi$ interactions between anthracene and benzimidazole rings in the solid. The same imidazolium salt was employed for the preparation of $[\text{Ag}(\text{NHC})_2]^+$ type compound **I-32**.⁶⁸ Compound **I-33a** with *N,N'*-dineopentyl substituents was synthesized with a high yield, and the solid state structure analysis indicated an interaction between $\text{Ag}(\text{I})$ and the aryl π -bond.⁶⁹ A bulky 1,3-dibenzhydrylbenzimidazolium bromide was utilized to synthesize $\text{Ag}(\text{I})-\text{NHC}$ complex **I-33b**, which was further used to prepare $\text{Pd}(\text{II})-\text{NHC}$ complexes.⁷⁰ However, on directly reacting $\text{Pd}(\text{OAc})_2$ with this bulky imidazolium bromide, an unprecedented $\text{Pd}(\text{II})-\text{NHC}$ complex was produced, which had an *N*-coordinated benzimidazole transformed from one NHC ligand. In other words, the Ag carbene transfer route provides cleaner and more predictable

Scheme 9

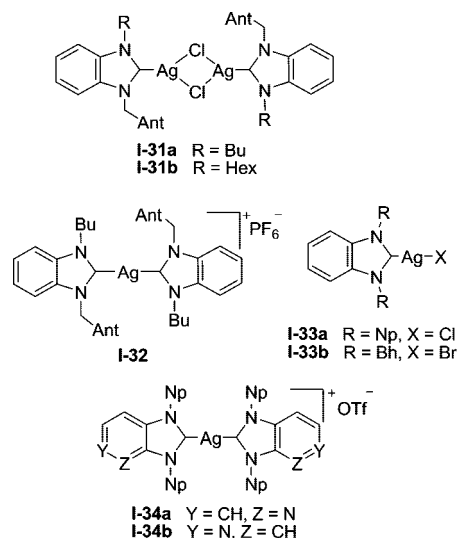

Scheme 10

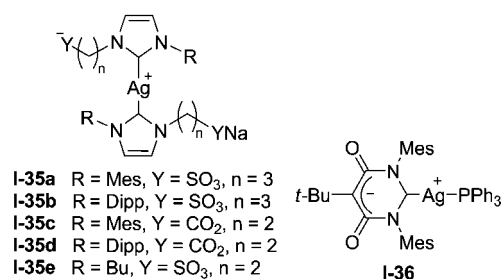

$\text{Pd}(\text{II})-\text{NHC}$ products than a direct reaction of the precursor with $\text{Pd}(\text{OAc})_2$. Heinicke and co-workers devoted their attention to the asymmetrically annulated $\text{Ag}(\text{I})-\text{NHC}$ s **I-34**.⁷¹ Complexes **I-34a** and **I-34b** were synthesized by the free carbene route and used in preparing $\text{Rh}(\text{I})-\text{NHC}$ complexes. The electron-withdrawing nature of the NHCs in **I-34** is reflected by the downfield $^{13}\text{C}_{\text{NHC}}$ δ values at ca. 193 ppm. The corresponding free carbene ligand was studied using photoelectron spectroscopy and theoretical calculations.

2.3.2. Zwitterionic Mono-NHC Ligands

Scheme 10 gives the $\text{Ag}(\text{I})-\text{NHC}$ s prepared from zwitterionic precursors. Water-soluble compounds **I-35a–e** were synthesized, where the imidazolium had one alkylsulfonate or alkylcarboxylate side arm together with a Mes, Dipp, or Bu side arm.⁷² These NHCs are negatively charged; incorporating two NHCs to a $\text{Ag}(\text{I})$ requires an additional cation to balance the charge of the $[\text{Ag}(\text{NHC})_2]^-$ type complexes. They are hydrophilic enough to dissolve in water. Zwitterionic $\text{Ag}(\text{I})-\text{NHC}$ **I-36** was synthesized by deprotonating a six-membered pyrimidinum betaine to form a malo-NHC (pyrimidinummalonate), followed by reaction with $(\text{PPh}_3)\text{AgOTf}$.⁷³ The electron-withdrawing nature of the malo-NHC in **I-36** leads to a downfield $^{13}\text{C}_{\text{NHC}}$ δ value of 199.4 ppm, comparable to those of **I-1**, **I-2**, and **I-34**.

2.3.3. Chiral Mono-NHC Ligands

Chiral $\text{Ag}(\text{I})-\text{NHC}$ complexes **I-37–I-47** are displayed in Scheme 11. An enantiomerically pure amino acid derived NHC participated in generating $\text{Ag}(\text{I})-\text{NHC}$ complex **I-37**.⁷⁴ It has been used as a transfer agent in reactions involving asymmetric metal complex catalysts. Prepared through the

Scheme 11

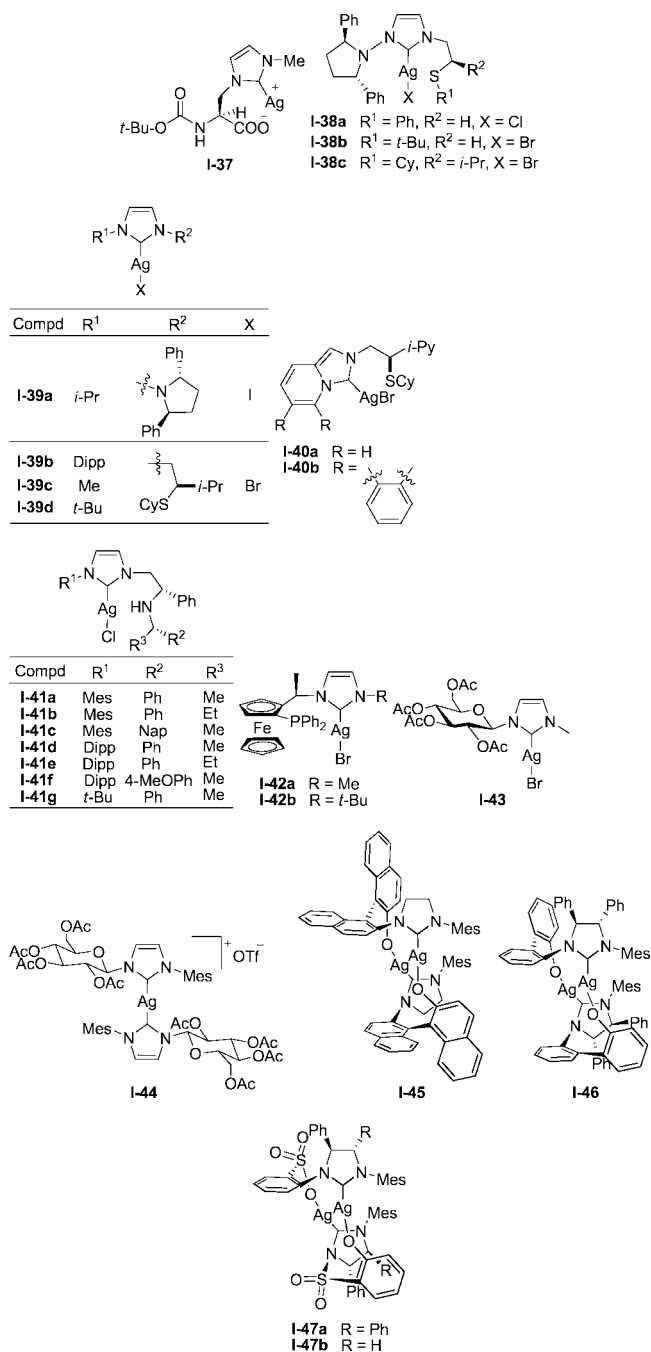

Ag₂O method, compounds **I-38** and **I-39a** contain a chiral *N-trans*-1-[(2*S*,5*S*)-2,5-diphenylpyrrolidin-1-yl] substituent, and **I-39b–d** have a chiral thioether N-side arm.^{75,76} Complex **I-39a** was used to synthesize Rh(I)– and Ir(I)–NHC complexes; the others were used to prepare Pd(II)–NHCs. The chiral thioether N-side arms of **I-40a** and **I-40b** play the role of a potential coordinating site in the formation of Pd(II)– and Rh(II)–NHC complexes, which are catalysts for asymmetric allylic alkylation.⁷⁶ Complexes **I-41** with a chiral amine derivative at the imidazole N-position were employed for the *in situ* generation of Pd(II) complexes to catalyze allylic alkylations.⁷⁷ Compounds **I-42**, containing *N*-diphenylphosphinoferrrocenyl-functionalized NHCs were used to prepare Pd(II)–NHCs as catalysts for allylic aminations with up to 80% enantiomeric excess (ee) values.⁷⁸ In a different approach, a sugar-modified NHC–Ag(I) complex **I-43** was synthesized and used for Ir(III)–NHC

preparation.⁷⁹ When a weak base, 1,8-diazabicycloundec-7-ene (DBU) was employed, sugar-modified [Ag(NHC)₂]⁺ type complex **I-44** was obtained by reacting the *in situ* generated NHC with AgOTf.⁸⁰ This compound was subsequently put to use in the preparation of two Pd(II)–NHC complexes. Intriguingly, direct deprotonation of the imidazolium salt followed by addition of Pd(II) sources failed to yield the Pd(II)–NHC, further demonstrating the advantage of the Ag–carbene transfer route.

Hoveyda's group continued to synthesize Ag(I)–NHC complexes **I-45–I-47** with chiral saturated NHC ligands, which were used as sources of chiral NHC to generate Cu(I)–NHC complexes for catalytic reactions.^{81,82}

2.3.4. Mono-NHC Ligands with P- and N-Donor Side Arms

Scheme 12 shows Ag(I)–NHCs in which the NHCs have functionalized P- or N-donor side arms.^{83–93} These P- or N-donor-functionalized groups may provide additional binding sites. Complexes **I-48** with NHCs of *N*-alkyl-*N'*-(2-phosphinoethyl)-benzimidazol-2-ylidenes, were synthesized for the generation of Pd(II) and Pt(II) complexes with C,P-bidentate NHCs.⁸³

Complexes **I-49–I-64** are N-donor-functionalized Ag(I)–NHC complexes. Compound **I-49** containing an *N*-pyridyl substituent forms a simple [Ag(NHC)₂]⁺ type complex with dangling pyridines.⁸⁴ Recently, *N*-picolyl imidazolium salts have been used to prepare Ag(I)–NHC complexes **I-50**.^{85a} These complexes were then applied to synthesize Ir(III)–,^{85a} Rh(I)–,^{85b} and Pd(II)–NHCs.^{85c} The NHC in compound **I-51** has a benzimidazolyl side arm.⁸⁶ The solid-state structure of this compound revealed an unusual trinuclear structure, in which the central carbene-supported Ag(I) was flanked by two Ag(I) ions coordinated to benzimidazole. Compound **I-51** was utilized to prepare a C,N-bidentate Pd(II)–NHC complex as catalyst applied in Suzuki-coupling reaction. *N*-(Aryl)imino-functionalized NHC complexes **I-52** have been studied and employed to synthesize Pd(II)–NHC complexes.⁸⁷ The *t*-butyloxycarbonyl (Boc)-protected 1-(2-aminoethyl)-3-methyl imidazolium salts were used to form Ag(I)–NHC complexes with three different bonding motifs in the solid state. This constituted (1) compounds **I-53a** and **I-53b** consisting of a [Ag(NHC)₂]⁺ type cation with a AgI₂[–] or a PF₆[–] anion, respectively, (2) compound **I-53c** comprising two [Ag(NHC)₂]⁺ type cations and a Ag₂I₄^{2–} anion, and (3) compound **I-54** being a neutral polymeric stair-case Ag(I)–NHC complex composed of extended Ag₄I₄ cores sandwiched by NHCs.⁸⁸ The ball and stick diagram of **I-54** is given alongside for a better viewing of the staircase structure. Pulsed gradient spin echo (PGSE) NMR experiments were employed to investigate the hydrodynamic dimension of the imidazolium salts and silver complexes and, consequently, to gain information on the aggregation level in solution. Complemented by nuclear Overhauser effect (NOE) NMR, information was obtained on anion–cation relative orientation in aggregation. The NHC in compound **I-55** has a potential three-N-donor chelating side arm.¹¹⁰ This trinuclear complex consists of a central [Ag(NHC)₂]⁺ type moiety flanked by two fragments of Ag(I) ions coordinated with four N donor atoms, including one acetonitrile molecule from solvent. There is a weak intermolecular Ag⋯π interaction (ca. 2.928 Å) forming an infinite 1-D chain. *N*-(2-Pyrimidyl)-substituted Ag(I)–NHC complexes **I-56**,⁸⁹ **I-57**,⁸⁹ and **I-58**⁹⁰ were designed recently. XRD analysis of ionic complex **I-56** shows that the two

Scheme 12

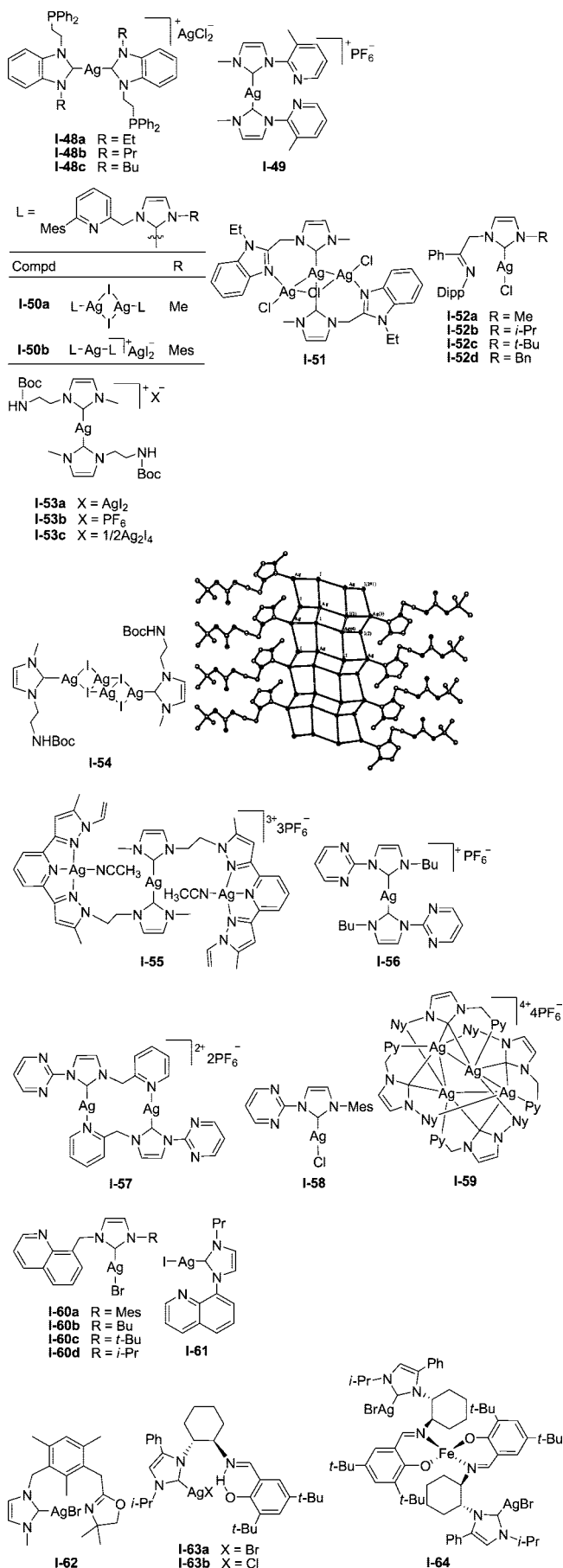

pyrimidines are approximately coplanar with their attached imidazole rings and the butyl groups point toward the same side of the coordination plane. This complex was used to generate a Pd(II)–NHC complex. The NHC in compound **I-57** has a 2-pyrimidyl and a picolyl side arm. Dinuclear complex **I-57** forms a metallocycle, where each Ag ion is coordinated by a pyridine and an NHC. A Ag···Ag interaction with a distance of ca. 3.131 Å was found. Complex **I-57** was also utilized to prepare a Pd(II)–NHC complex. The neutral Ag(I)–NHC complex **I-58** was employed to prepare C,N-chelated Ni(II)–, Pd(II)–, and Pt(II)–NHCs. A tetranuclear Ag(I) complex **I-59**, having an NHC with a picolyl and a Ny (see section for abbreviations) side arm, displays a planar Ag₄ core structure in the solid.⁹¹ The four Ag···Ag bonds are supported by four NHC ligands in η²-bonding mode. It was used to prepare Pd(II)–NHC complexes. N-Quinolyl-functionalized Ag(I)–NHC complexes **I-60** were synthesized and used to prepare Pd(II)–,⁹² Rh(I)–, and Ir(I)–NHC⁹³ complexes with dangling quinoline. Complex **I-61** was synthesized and used to prepare a Pd(II)–NHC chelate complex.⁹² Compound **I-62**, in which an NHC and an oxazoline are bridged by a 2,4,6-trimethylbenzene spacer, has also been prepared.⁹⁴ Two unusual complexes, **I-63** and **I-64**, were synthesized.⁹⁵ Compound **I-63** comprising a free phenoximine moiety and an [Ag(NHC)Br] fragment was employed to synthesize C,N-bidentate Rh(I)–NHC complexes. Direct reaction of **I-63** with [Fe(N(SiMe₃)₂)₂] in an attempt to synthesize a C,N,O-coordinated Fe(I)–NHC complex by the Ag–carbene transfer route produced **I-64** instead.

2.3.5. Multi-NHCs Linked by Spacers

Scheme 13 shows multi-NHC–Ag(I) complexes prepared from azolium cations joined by alkyl, etheryl, or aryl linkers. An oligoether-linked bis-benzimidazolium salt was used to synthesize Ag(I)–NHC complex **I-65**.⁹⁶ A similar imidazol-2-ylidene compound has been reported earlier.⁹⁷ The NHC crown in **I-66** has four NHCs linked by –(CH₂)₃– groups in the form of a macrocycle.⁹⁸ This homoleptic complex **I-66** was synthesized together with the Cu(I) and Pd(II) analogues. The ligand flexibility allows two Ag(I) ions to be incorporated into the macrocyclic cavity. The two cationic [Ag(NHC)₂]⁺ moieties exhibit an intramolecular Ag···Ag interaction of ca. 2.835 Å. Association of **I-66** cations fabricates a 1-D chain via a weak intermolecular Ag···Ag interaction of ca. 3.476 Å. It is interesting to note that this polymeric Ag chain is composed of cationic [Ag(NHC)₂]⁺ moieties. A sterically rigid tris-imidazolium cage was designed as an NHC precursor to form Ag(I)–NHC complex **I-67**, with a Ag(I) trapped in the cage by two NHCs.⁹⁹ Complexes **I-68** with two NHCs connected by a 2,4,6-trimethylbenzene spacer were synthesized. These compounds have two neutral [Ag(NHC)(halide)] moieties.⁹⁴ They were used to synthesize bidentate Pd(II)–NHC complexes.

Complexes **I-69** and **I-70** with two benzimidazol-2-ylidene moieties connected by a durene as the spacer have been reported recently.¹⁰⁰ The different N-alkyl side arms, ethyl in **I-69** and butyl in **I-70**, cause a conformational change. The two neutral [Ag(NHC)Br] moieties in **I-69** are associated with two bridging Br⁻ and a weak Ag···Ag interaction (ca. 3.095 Å) to form a metallocycle. On the other hand, the [Ag(NHC)Cl] moieties in **I-70** are antiparallel and almost perpendicular to the durene. Intermolecular π–π stacking interactions between benzimidazole rings have been found

Scheme 13

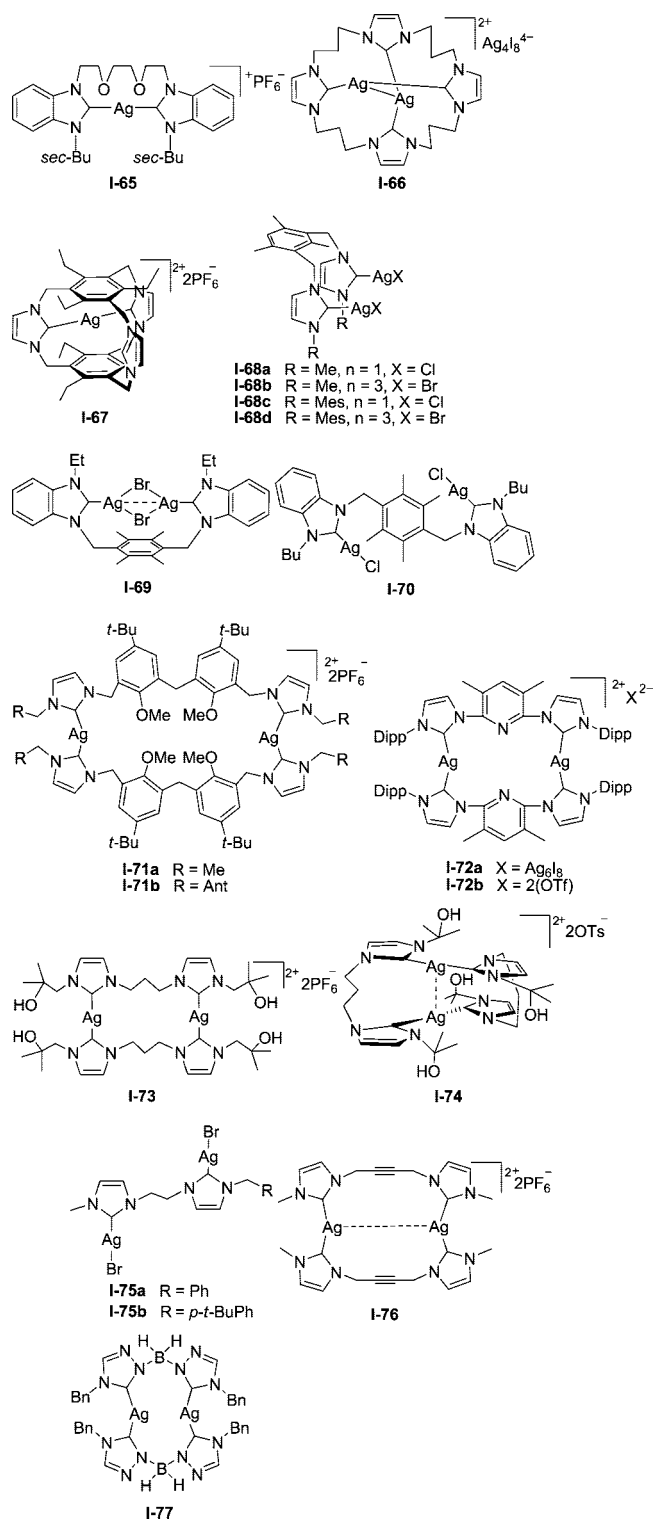

in both **I-69** and **I-70**. Interesting calix[4]arene like complexes **I-71** have been reported.¹⁰¹ This compound has two $[\text{Ag}(\text{NHC})_2]^+$ type moieties linked by *p-t*-butyl anisole moieties. It thus forms a cavity serving as an efficient [60]fullerene host. Dinuclear compounds **I-72** have bridging bis-NHC ligands, each of which has a 3,5-dimethylpyrid-2,6-yl linker.¹⁰² Interestingly, while compound **I-72a** was synthesized via the Ag_2O route, compound **I-72b** was prepared via the reverse transmetalation of a Ni(II)–NHC complex. This is the first report of a reverse Ni– to Ag–NHC transmetalation. Compound **I-72a** was reacted

Scheme 14

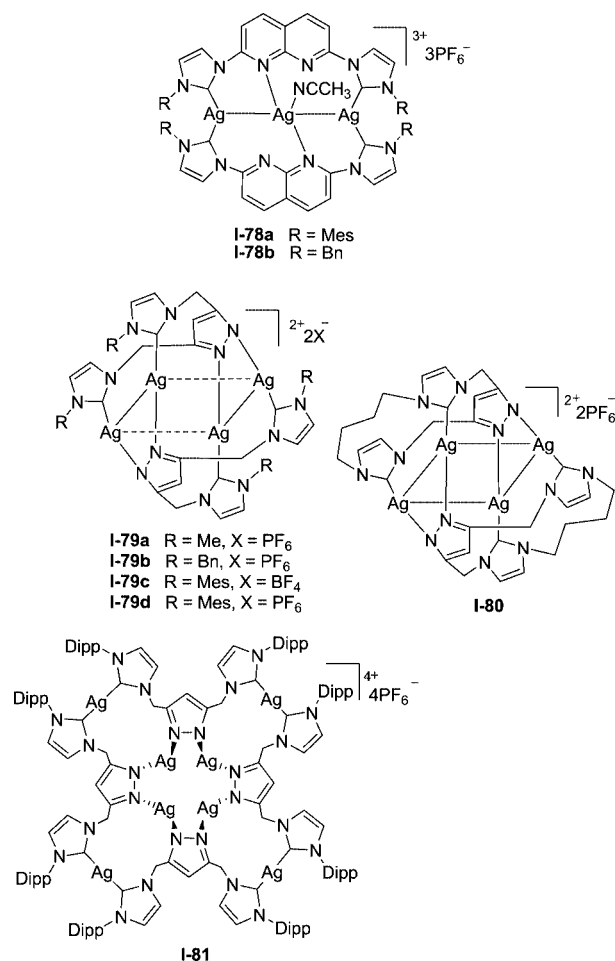

with $\text{NiBr}_2(\text{DME})$ to prepare a Ni(II)–NHC complex whose $(\text{Ag}_6\text{I}_6)_2^-$ anion adopts an unusual arrangement of Ag atoms in a planar six-membered ring.

Complexes **I-73** with PF_6^- and **I-74** with OTs^- anions were prepared and structurally characterized.¹⁰³ Both compounds have two $-(\text{CH}_2)_3-$ bridged $[\text{Ag}(\text{NHC})_2]^+$ type moieties, each with two terminal hydroxyl pendant arms. The anions cause a considerable difference in the solid-state structure. The compound **I-73** is “shell-like” with the alcoholic side arms in the same orientation to form a solvent pocket. On the other hand, the two linearly coordinated $[\text{Ag}(\text{NHC})_2]^+$ cations in **I-74** arrange in a crossed conformation with a weak $\text{Ag}\cdots\text{Ag}$ interaction of ca. 3.074 Å. Complexes **I-75**, presumably having two different neutral $[\text{Ag}(\text{NHC})\text{Br}]$ moieties bridged by a $-(\text{CH}_2)_3-$ linker, were employed to prepare Pd(II)–NHC complexes for Suzuki-coupling reaction.¹⁰⁴ A twisted macrocyclic complex **I-76** was prepared, where two $[\text{Ag}(\text{NHC})_2]^+$ moieties were connected by two rigid $-\text{CH}_2-\text{C}\equiv\text{C}-\text{CH}_2-$ linkers.¹⁰⁵ A dinuclear complex **I-77** was prepared from a bis(triazolium) salt, which has two benzyl-1,2,4-triazoles connected by a dihydroborate linker.¹⁰⁶ This compound has two Ag(I) ions bridged by two negatively charged bis-NHCs to form a neutral metallocycle. No crystal structure results are available. A similar compound with imidazole-based NHC has been reported.¹⁰⁷ Compound **I-77** was also used to prepare an Au(I)–NHC complex.

Scheme 14 displays multinuclear Ag(I)–NHC complexes **I-78**–**I-81**. The bis-NHC ligands in these complexes consist of two NHCs linked by different *N*-heterocycles. Trinuclear

Scheme 15

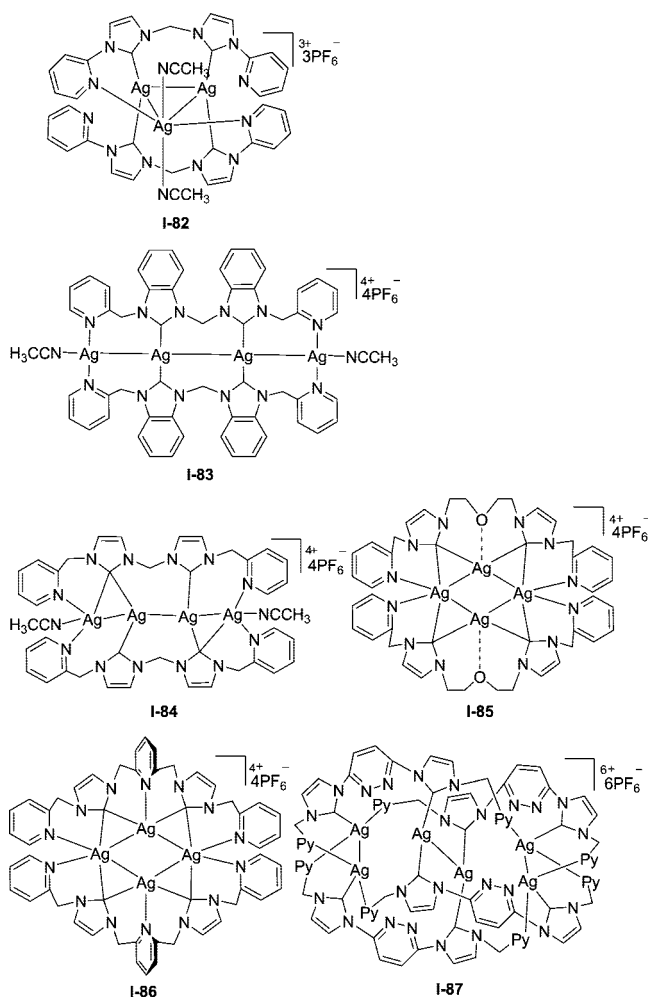

Ag(I)–NHC complexes **I-78** have been synthesized, where the tridentate ligand comprises two terminal NHCs and an N-donor naphthyridin-1,8-diyl linker.¹⁰⁸ The central $[\text{Ag}(\text{Napy})_2]^+$ moiety and the two flanked $[\text{Ag}(\text{NHC})_2]^+$ moieties arranged to give a linear Ag_3 core. Compounds **I-79–I-81** possessed a type of tetradentate ligand consisting of two NHCs and a pyrazol-3,5-diyl linker.^{109–111} Compounds **I-79**^{109–111} and **I-80**¹¹¹ are tetranuclear compounds. The general structures of these compounds could be viewed as a planar Ag_4 core sandwiched between two tetradentate NHC ligands. For complexes **I-79a**,¹⁰⁹ **I-79d**,¹¹¹ and **I-80**,¹¹⁰ the four Ag ions arranged in a near rectangular shape via two sets of $\text{Ag}\cdots\text{Ag}$ interactions. A similar framework but with equal $\text{Ag}\cdots\text{Ag}$ interactions is seen for compounds **I-79b** (ca. 3.113 Å) and **I-79c** (ca. 3.116 Å).¹¹⁰ Octanuclear complex **I-81** has a double metallocrown structure.¹¹¹ The outer metallocrown consists of four $[\text{Ag}(\text{NHC})_2]^+$ type moieties, and a smaller inner metallocrown comprises four $[\text{Ag}(\text{pyrazol})_2]^+$ type moieties. Complex **I-81** was not stable in solution; ¹H NMR studies showed that the octanuclear **I-81** was in equilibrium with a tetranuclear and a hexanuclear species. Intriguingly, compounds **I-79** and **I-81** have a seemingly identical ligand, yet different structures are found, possibly due to the difference in the steric bulkiness of *N*-mesityl and *N*-Dipp substituents.

A trinuclear complex (**I-82**),¹¹² four tetranuclear complexes (**I-83–I-86**)^{112,113}, and a hexanuclear (**I-87**)¹¹³ complex are shown in Scheme 15. The general feature of the NHC ligands in this category is that two pyridyl-functionalized NHCs are

bridged by $-(\text{CH}_2)-$, $-(\text{CH}_2)_2\text{O}(\text{CH}_2)_2-$, lutiden-2,6-diyl, or pyridazin-3,6-diyl groups. Compound **I-82** had a triangular Ag_3 core, of which two Ag ions adopted a $[\text{Ag}(\text{NHC})_2]^+$ type bonding mode and the other a $[\text{Ag}(\text{Py})_2]^+$ type bonding mode. The latter had two additional coordinating acetonitrile molecules. The $\text{Ag}\cdots\text{Ag}$ distances between $[\text{Ag}(\text{NHC})_2]^+$ type and $[\text{Ag}(\text{Py})_2]^+$ type were short (ca. 2.955, 2.966 Å), while that between the two $[\text{Ag}(\text{NHC})_2]^+$ type was long (ca. 3.299 Å). The Ag_4 core in compound **I-83**¹¹² was arranged in a zigzag fashion, but that in **I-84** was linear. Both were homoleptically bonded by two tetradentate ligands, consisting of two inner NHC and two outer pyridine ligands. Each of the two terminal Ag ions has an additional coordinating acetonitrile molecule. While the $\text{Ag}\cdots\text{Ag}$ bonds in **I-83** were of similar strength (ca. 3.1 Å), in **I-84** the terminal $\text{Ag}\cdots\text{Ag}$ interactions (ca. 2.911 Å) were stronger than the central one (ca. 3.228 Å). The bonding fashion of benzimidazole-2-ylidene was found normal in **I-83**, but an η^2 -type bonding was seen for imidazole-2-ylidene in **I-84**. Also, the change of N-substituent from pyridyl (**I-82**) to picolyl (**I-84**) led to compositional and structural differences, as shown. It is interesting to note that the Ag_4 core in **I-84** adopts a linear geometry, and those in **I-85** and **I-86** adopt a near square planar geometry. It seems that the O or N donor and the longer length in the linker of **I-85** and **I-86** make the difference. NHCs with η^2 -bonding modes were also observed in **I-85** and **I-86**. Complex **I-87** had a Ag_6 core supported by four potentially hexadentate ligands, in which two picolyl-functionalized NHCs were linked by a pyridazin-3,6-diyl group. The long $\text{Ag}\cdots\text{N}$ distances (the shortest is ca. 2.801 Å) showed that the pyridazine rings did not participate in the Ag coordination. This complex shows a pairwise $\text{Ag}\cdots\text{Ag}$ interaction. Most of these multinuclear complexes are luminous.

2.4. The Ag_2O Route

2.4.1. Feasibility

The advantages of the Ag_2O technique to synthesize Ag(I)–NHCs are as follows: (1) Ag_2O is relatively stable and readily accessible; (2) the reactions can be carried out under air atmosphere at room temperature; (3) solvent pretreatments and strong bases are not required; (4) chirality can be retained.¹¹⁴ A few failures and unexpected results were known; reactions at times were carried out at higher temperature or for longer time. The efficiency of this method may depend on the acidity^{115–118} and steric hindrance^{63,67–69,72} of the azolium salts and the nucleophilicity^{115,119–121} of the NHCs.

An interesting example that evidenced the influence of acidity on the feasibility of the Ag_2O route is known.¹²² Specifically, while the Ag_2O route is applicable to *N,N'*-diferrocenyl imidazolium salt, it failed for the *N,N'*-diferrocenyl imidazolium salt (Scheme 16, eq 1), which was attributed to the insufficient acidity of the C^2 proton of the latter. As another example, the reactivity of Ag_2O with imidazolium salt of halide anions is superior to those with salts of noncoordinating anions like BF_4^- and PF_6^- .¹²³ Since the C^2 proton forms stronger hydrogen bonds with halides than with BF_4^- and PF_6^- , the halide salts are considered more acidic than the BF_4^- and PF_6^- salts.¹¹⁶ Again, acidities of the NHC precursors play a role. The functional electron-withdrawing groups at $\text{C}^{4/5}$ positions of the imidazolium backbone affect the acidity of the C^2 proton and thus the

Scheme 16

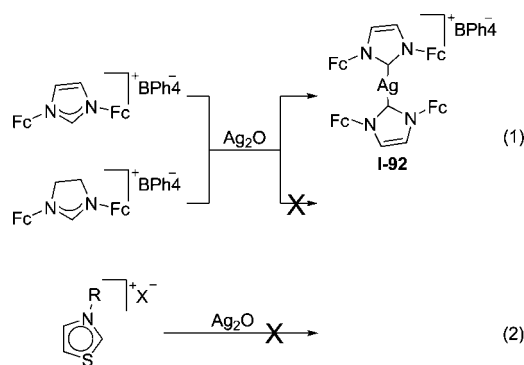

reactivity with Ag_2O .^{14c,42} For example, it takes 12 h to synthesize compounds **I-2** with unsubstituted $\text{C}^{4/5}$,⁴² while the reaction time is reduced with $\text{C}^{4/5}$ -substituents of Cl (2 h), NO_2 (3 h), or CN (4 h) groups. This signifies that the C^2 proton is more acidic if the $\text{C}^{4/5}$ -substituents have better electron-withdrawing ability. A similar result was also found for compounds **I-20**.^{14c} The steric bulk around the azolium cations also changes the efficiency of the Ag_2O route.¹²⁴ As simple methyl or ethyl *N*-substituted imidazolium salts reacted readily with Ag_2O , bulkier Ant^{67,68,101} or Mes¹²⁵ groups required higher temperature, longer reaction time, or both. An *N,N'*-dialkyl imidazolium salt with a hexadecyl chain needed 12 h to react with Ag_2O ,¹⁵ whereas a salt with an ethyl chain demanded less than 2 h.⁵⁴ As a different example, thiazolium halides have a more acidic C^2 proton than the imidazolium and imidazolium salts.¹²⁶ Yet thiazol-2-ylidene is too poor a nucleophile to be applied in the Ag_2O route.¹²⁷

2.4.2. Complications

Upon prolonged reaction of more than one equivalent of Ag_2O and *N,N'*-dialkyl imidazolium halide, the solution could develop a yellow color, which can be removed by active carbon.¹⁵ When conditions permitted, the reaction vessel at times was coated with a brown powdery solid and silver mirror. The yellow color has been attributed to the formation of Ag nanoparticles (NPs). Owing to its super-electron-donor property, bisimidazolidine, a carbene dimer, is utilized as a reducing agent in certain reactions.¹²⁸ Carbene dimer such as is generated during the reaction of imidazolium halide with excess Ag_2O may reduce the Ag(I) ion to Ag NPs protected by imidazolium or NHCs.

Different anions in the imidazolium salts might cause complications in the Ag_2O route. *N,N'*-dipyridyl imidazolium bromide failed to react with Ag_2O to produce Ag(I)–NHC; instead an undesired reaction involving base hydrolysis of the imidazole ring produce *N*-(pyridin-2-yl)-*N'*-(2-(pyridin-2-ylamino)vinyl) formamide (Scheme 17, eq 3).¹¹⁷ However, reacting the corresponding imidazolium tetrafluoroborate with Ag_2O in the presence of NaOH yielded compound $[\text{Ag}(\text{NHC})_2][\text{BF}_4]$ **I-93** (Scheme 17, eq 3).¹¹⁸ Apparently, the BF_4^- ion inhibited the hydrolysis of the imidazole ring, yet NaOH was required to accelerate the reaction.

Reactions of imidazolium salts with Ag_2O usually produce neutral $[\text{Ag}(\text{NHC})\text{X}]$ or ionic $[\text{Ag}(\text{NHC})_2][\text{AgX}_2]$ (Scheme 18, eq 4).⁵⁵ A dynamic equilibrium between these forms in solution has been proposed^{13,16,57a} and monitored by ¹³C NMR spectroscopy.^{13,63,129} Isolation of the neutral or ionic form mainly depends on the steric bulk of the NHC and the solvent

Scheme 17

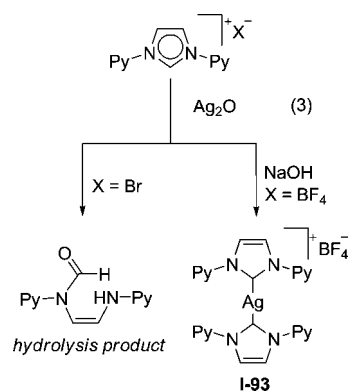

Scheme 18

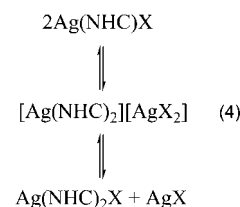

Scheme 19

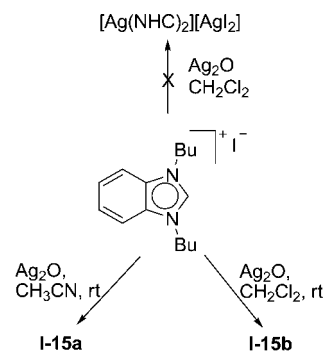

system. Generally speaking, bulkier NHC and less polar solvent would favor the neutral form.¹²⁹ In many cases, formation of Ag(I)–NHCs is accompanied by the precipitation of AgX, which leads to the isolation of nonstoichiometric $[\text{Ag}(\text{NHC})_2][(\text{AgX}_2)_n/\text{X}_{1-n}]$.^{15,124} Generating pure $[\text{Ag}(\text{NHC})_2]^+$ type salts through anion metathesis by employing anions such as BF_4^- , PF_6^- , $\text{B}(\text{Ph})_4^-$, or NO_3^- could avoid this complication. In a few cases, however, prolonged reaction time caused a complete precipitation of AgX and produced three-coordinated $[(\text{Ag}(\text{NHC})_2\text{X})]$ type compounds including a rare case of $[(\text{Ag}(\text{NHC})_2)_3\text{I}][\text{I}]_2$.^{55,130}

The solvent system in the Ag_2O method may give rise to complicated products in the presence of iodide anion. For example in Scheme 19, compound **I-15a** with $\text{Ag}(\text{CN})_2^-$ anion rather than the anticipated AgI_2^- was generated in acetonitrile.⁵³ Although the nature of this anion exchange reaction is not certain, the acetonitrile appears to be a likely source of CN^- . On the other hand, **I-15b** with AgCl_2^- anion was obtained in CH_2Cl_2 (Scheme 19). The exchange of I^-/Cl^- is probably due to the presence of CH_2Cl_2 .⁵⁴ Despite these complications, formation of iodide containing complexes such as $[\text{Ag}(\text{NHC})\text{I}]$,^{42,92,131} $[\text{Ag}(\text{NHC})_2][\text{AgI}_2]$,^{54,85,88} and many others in CH_2Cl_2 have been reported. Note also that Ag_2O used in the formation of **I-15** was prepared as a brown powder and two equivalents were employed.⁵³

Scheme 20

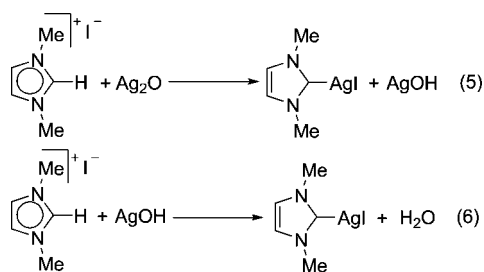

2.4.3. Theoretical Consideration

Recently, Peris, Lledós, and co-workers carried out DFT calculations to understand the mechanism of the Ag_2O route.³⁵ The system studied included two N,N' -dimethyl imidazolium cations, two iodide counterions, and Ag_2O in CH_2Cl_2 solvent. The results indicate that the reaction of two imidazolium salts with one Ag_2O to form two $[\text{Ag}(\text{NHC})\text{I}]$ molecules involves two deprotonations and two metalations. Namely, a Ag_2O molecule deprotonates an imidazolium cation, and then the $\text{Ag}(\text{I})$ coordinates with the carbene to generate the first $[\text{Ag}(\text{NHC})\text{I}]$ and AgOH (Scheme 20, eq 5). This AgOH further deprotonates a second imidazolium cation, followed by metalation to yield the second $[\text{Ag}(\text{NHC})\text{I}]$ and H_2O (Scheme 20, eq 6). All steps take place with low Gibbs activation energies. One driving force for the spontaneous formation of the first $[\text{Ag}(\text{NHC})\text{I}]$ is presumably the $\text{p}K_a$ difference between imidazolium cation and $[\text{Ag}_2\text{OH}]^+$, the protonated Ag_2O ; the formation of the strong $\text{Ag}(\text{I})\text{--NHC}$ bond constitutes another. The overall process of eq 5 is predicted to be exothermic. Although the subsequent deprotonation of a second imidazolium cation by AgOH is not energetically favorable, the exothermic formation of the second $\text{Ag}(\text{I})\text{--NHC}$ bond is the driving force to complete the second process. Calculations therefore predict that the Ag_2O reaction in this system would be facile. An experiment was performed to substantiate the theoretical calculations. A reaction between Ag_2O and N,N' -dimethylimidazolium iodide in $\text{DMSO-}d_6$ was followed by ^1H NMR spectroscopy. The reaction was almost complete upon mixing the reactants, consistent with the prediction. The calculations justify the advantage of using Ag_2O and may explain some previous experimental observations.

2.5. Applications

$\text{Ag}(\text{I})\text{--NHCs}$ have been utilized for several purposes. These include (1) NHC transfer reactions,^{81,114,132,136} (2) catalysis,^{43–45,81,82,133–136} (3) medicine,^{14b,c,57,137} and (4) nanomaterials.¹³⁸ In the following sections, we will discuss these applications.

2.5.1. $\text{Ag}(\text{I})\text{--NHCs}$ in NHC Transfer

As already mentioned, $\text{Ag}(\text{I})\text{--NHCs}$ have been extensively used to prepare other metal–NHCs through transmetalation (Scheme 21). Here we mention one recent development to demonstrate the delicacy of using $\text{Ag}(\text{I})\text{--NHC}$ complexes as carbene transfer agents. Crabtree and co-workers reported the preparation of $[\text{Ir}(\text{COD})(\text{NHC})(\text{NHC})]^+$ type complexes **I-94** and **I-95** via two sequential Ag –carbene transfers.¹³² Reaction of $[\text{Ir}(\text{COD})\text{Cl}]_2$ with $\text{Ag}(\text{I})\text{--NHCs}$ first produced $[\text{Ir}(\text{COD})(\text{NHC})\text{Cl}]$ type compounds,¹³⁹ which upon further reaction with $[\text{Ag}(\text{NHC})_2][\text{PF}_6]$ type compounds generated **I-94** with mixed imidazol-2-ylidene and triazol-

Scheme 21

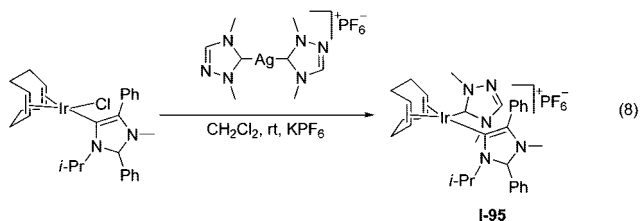
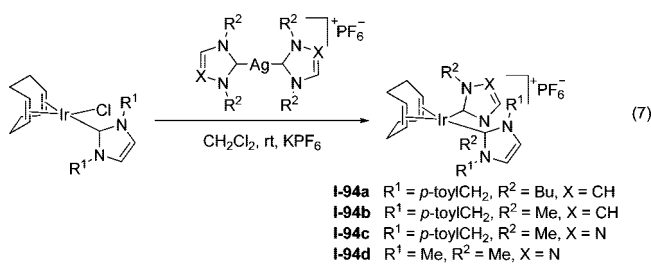

Scheme 22

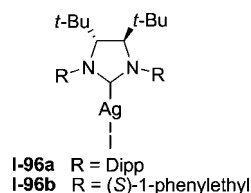

5-ylidene NHCs (eq 7). Similarly, **I-95** with mixed abnormal and normal NHCs was obtained (eq 8).

Retention of chirality through the Ag –carbene transfer route has been noticed in several cases.^{81,114,136} Herrmann's group synthesized chiral $\text{Ag}(\text{I})\text{--NHC}$ complexes **I-96** (Scheme 22) as precursors for two $\text{Rh}(\text{I})\text{--NHC}$ complexes. The chirality of the imidazolium salt was retained in the preparation of $\text{Ag}(\text{I})\text{--NHC}$ via the Ag_2O route and also in the $\text{Rh}(\text{I})\text{--NHC}$ formation.¹¹⁴ On the other hand, synthesizing a $\text{Rh}(\text{I})\text{--NHC}$ complex through the free carbene route led to chirality loss. This again demonstrated the superiority of the Ag_2O method in producing chiral NHC complexes. Chiral $\text{Ag}(\text{I})\text{--NHCs}$ also act as sources of chiral NHCs to improve the enantioselectivity of Cu -catalyzed organic transformations.^{81,136}

2.5.2. $\text{Ag}(\text{I})\text{--NHCs}$ in Catalysis

Peris, Fernandez, and colleagues first reported the utilization of a $\text{Ag}(\text{I})\text{--NHC}$ complex to carry out alkene diboration reactions,¹³³ which has been reviewed.^{14a} The attempt to utilize a $\text{Ag}(\text{I})\text{--NHC}$ complex to catalyze ring-opening polymerization (ROP) reactions was reported by Waymouth's and Hedrick's groups.¹³⁵ Free NHC generation was proposed to be responsible for this reaction instead of $\text{Ag}(\text{I})\text{--NHC}$ promoted catalysis. Ghosh's group in a continuing study suggested an alternative reaction pathway involving silver ion mediated polymerization.⁴³ They found that when $\text{Ag}(\text{I})\text{--NHCs}$ were used under solvent-free melt conditions, polylactide with narrow molecular weight distribution was obtained.^{43,45,134}

2.5.3. $\text{Ag}(\text{I})\text{--NHCs}$ in Medicine

Youngs' group pioneered the use of $\text{Ag}(\text{I})\text{--NHCs}$ in medicine.¹³⁷ $\text{Ag}(\text{I})\text{--NHCs}$ can slowly release Ag ions to solution. Water-soluble pincer NHC complexes have been shown to slow the releasing process, thus increasing the

Scheme 23

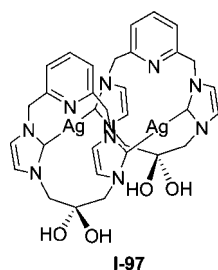

bactericidal activities.¹³⁷ An encapsulated Ag(I)–NHC complex, **I-97**, in nanofiber has been found as a promising combination of sustained release and effective delivery of Ag ions with maximum bactericidal activity over a longer period of time than aqueous silver.^{137b} A caffeine-derived Ag(I)–NHC complex demonstrated profound antimicrobial activities, especially against highly resistant opportunistic respiratory tract pathogens from the lungs of cystic fibrosis patients, including members of the *Burkholderia cepacia* complex.^{14b,57b} These studies have been extensively covered in the reviews by Youngs' group (Scheme 23).^{14b}

Antibacterial activities of complex **I-19** against *Bacillus subtilis* and *Escherichia coli* were studied through measuring the bacterial growth at different times.²³ The growth of Gram-positive *Bacillus subtilis* was inhibited by **I-19** but not that of Gram-negative *Escherichia coli*. Complex **I-19** did not show any activity to inhibit cervical cancer (HeLa cell).

The stability of complexes **I-20a–c** in water and their correlation with antimicrobial activity against bacterial strains associated with cystic fibrosis and chronic lung infections has been examined. The compound **I-20b**, having chlorine substituents on the C^{4/5} of the imidazole ring, showed a moderate initial dissociation, followed by continuous release of Ag(I) ions.^{14c} It has been proposed that the chloride group shows σ -withdrawing and π -donating ability, stabilizing the Ag(I)–NHC complex **I-20b**. This compound appears to be bactericidal at concentrations achievable clinically for a panel of pathogens, primarily respiratory isolates of *Pseudomonas aeruginosa*, *Burkholderia species*, and *Escherichia coli*.

2.5.4. Ag(I)–NHCs in Nanomaterials

Ag(I)–NHC complexes with long chain N-substituted NHCs exhibited liquid crystal properties when (1) mixed with imidazolium salt or (2) decomposed to give mixed AgX_2^- and X^- anions.¹⁵ While addition of excess Ag_2O to these compounds generated stable Ag NPs, reduction of these complexes by NaBH_4 in a biphasic system also gave spherical Ag NPs. These Ag NPs were stabilized either by the long chain imidazolium cations or by the NHCs.

Polymeric imidazolium salt in submicrometer spheres was fabricated and reacted with Ag_2O to produce a Ag(I)–NHC polymer (**I-98**, Scheme 24).¹³⁸ This polymer was used to produce Cu(I)– and Pd(II)–NHC polymers. X-ray photoelectron spectroscopy (XPS) was used to characterize these polymers. These experiments again demonstrated the effectiveness of the Ag_2O technique coupled with transmetalation. Further research into these submicroplatforms may lead to the development of polymer-supported metal–NHC catalysts.

Scheme 24

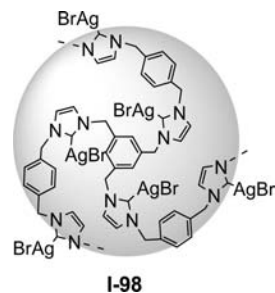

3. Au(I)– and Au(III)–NHCs

3.1. Historical Background

In 1974, Lappert's group reported the formation of ionic $[\text{Au}(\text{NHC})_2][\text{anion}]$ type complexes from electron-rich olefins.¹⁴⁰ In the same year, Fehllhammer's group described the generation of Au(I)– and Au(III)–NHC complexes through the spontaneous cyclization of isocyanide ligands.¹⁴¹ In 1989, Burini's group unexpectedly isolated Au(I)–NHC complexes through reaction of $[\text{Au}(\text{PPh}_3)\text{Cl}]$ with lithiated benzylimidazoles, followed by protonation.¹⁴² Later, Raubenheimer's group was able to extend this strategy to form *N*-alkyl-substituted Au(I)–NHC complexes.¹⁴³ They further synthesized Au(III)–NHCs through oxidative addition of halogens to Au(I)–NHCs.¹⁴⁴ Lock and co-workers also described the unexpected formation of a Au(I)–NHC complex when tris(4,5-dimethylimidazol-2-yl)phosphine was allowed to react with tetrachloroaurate.¹⁴⁵ In 1997, Lin's group obtained the first series of liquid crystalline Au(I)–NHC compounds by reacting long chain substituted *N,N'*-dialkyl benzimidazolium salts with $[\text{Au}(\text{SMe}_2)\text{Cl}]$ under basic phase-transfer catalysis conditions.¹⁴⁶ In 1998, they also developed a technique to synthesize Au(I)–NHCs by employing Ag(I)–NHCs as carbene transfer agents.¹³ This provided a very convenient method for access to Au(I)–NHCs. The next year, $[\text{Au}(\text{NHC})\text{Cl}]$ was used to prepare many luminous Au(I) complexes.¹⁴⁷ Unsupported $\text{Au}\cdots\text{Au}$ interaction and its relation to a low-energy emission have been addressed. Herrmann's group pioneered the utilization of Au(I)–NHCs as catalysts for the addition of water to 3-hexyne in 2003.¹⁴⁸ In 2004, Berners-Price, Baker, and co-workers reported the antimetochondrial activities of Au(I)–NHCs.¹⁴⁹ The same year, Çetinkaya's group investigated the antimicrobial activities of Au(I)–NHCs.¹⁵⁰ The easy accessibility of Au(I)–NHCs and the boom in using gold complexes in catalysis have led Au(I)– and Au(III)–NHCs into a flourishing field. Three review articles on Au(I)–NHCs have appeared recently.^{18,28,29} In 2005, Lin's group summarized the syntheses, characterizations, properties, and applications of Au(I)–NHC complexes.²⁸ In 2008, Raubenheimer's group in a broader article reviewed gold carbene complexes, concerning the preparation, medical applications, and types of bonding of Au(I)– and Au(III)–NHC complexes.²⁹ In the same year, Nolan's group presented a review on the Au(I)– and Au(III)–NHC complexes in catalysis.¹⁸

3.2. General Synthetic Methods

Scheme 25 outlines the general methods employed to prepare Au(I)–NHC complexes: (1) cleavage of electron-rich double bonds, (2) protonation or alkylation of gold carbenate compounds, (3) transfer of NHCs from group 6, 7, and 11 complexes, and (4) reaction of Au(I) sources with

Table 2. $^{13}\text{C}_{\text{NHC}}$ δ Values for Au(I)– and Au(III)–NHC Complexes

compd	δ , ppm	compd	δ , ppm
II-1 ^{154a}	171.9 ^a	II-50b ¹⁶²	167.6 ^a
II-2 ^{154a}	168.7 ^a	II-52 ¹⁶³	169.2 ^a
II-3 ^{154a}	169.9 ^a	II-53 ¹⁶³	169.4 ^b
II-4a ^{154b,d}	168.2, ^a 167.6 ^f	II-54 ¹⁶³	169.2 ^a
II-4b ^{154b}	172.4 ^a	II-55 ¹⁶³	165.7 ^a
II-4c ^{154b}	179.9 ^a	II-56 ¹⁵⁸	199.2 ^b
II-4d ^{154b}	174.7 ^a	II-57 ^{164a}	183.3 ^g
II-4e ^{154b}	177.3 ^a	II-58 ^{164b}	181.8 ^g
II-4f ^{154b}	181.5 ^a	II-59 ^{164b}	182.5 ^g
II-4g ^{154b}	166.4 ^a	II-60 ^{164a}	180.2 ^g
II-4h ^{154b}	166.2 ^a	II-61 ^{164a}	182.0 ^g
II-5a ^{154a,c}	166.1, ^a 168.0 ^b	II-62 ^{164a}	180.4 ^g
II-5b ²⁰	172.1 ^a	II-63 ^{164a}	177.2 ^g
II-6a ^{154a,c}	173.6, ^a 173.4 ^b	II-64 ^{164a}	182.5 ^a
II-6b ²⁰	176.7 ^a	II-66 ^{165a}	182.5 ^b
II-7a ^{154c}	175.1 ^b	II-67 ^{165b}	186.0 ^f
II-7b ²⁰	179.0 ^a	II-68 ⁸⁴	184.8 ^f
II-8a ^{154c}	166.3 ^b	II-69 ^{165c}	183.6 ^f
II-8b ²⁰	170.2 ^a	II-70 ⁴⁸	183.2 ^a
II-9a ¹⁵⁵	170.8 ^a	II-71 ⁴⁸	182.3 ^a
II-9b ¹⁵⁵	171.5 ^a	II-73 ¹⁵²	187.4 ^a
II-10 ⁴⁴	170.2 ^a	II-74 ⁹⁷	183.4 ^g
II-11 ⁴⁶	169.2 ^a	II-75 ⁹⁷	183.8 ^g
II-12a ⁴⁵	167.6 ^a	II-76 ⁹⁷	183.3 ^g
II-12b ⁴⁵	170.1 ^a	II-77 ⁹⁷	182.8 ^g
II-13 ²³	169.2 ^a	II-78 <i>cis</i> - ²⁷	187.7 ^h
II-14 ⁴⁹	184.4 ^a	II-78 <i>trans</i> - ²⁷	187.7 ^h
II-15a ⁸⁷	172.6 ^a	II-79 ^{165b}	185.0 ^f
II-15b ⁸⁷	171.3 ^a	II-80 ^{165b}	166.5 ^f
II-15c ⁸⁷	171.2 ^a	II-83 ¹¹³	166.3 ^g
II-15d ⁸⁷	172.9 ^a	II-84 ^{166a}	187.4 ^f
II-17a ^{154c}	195.0 ^a	II-85 ^{166a}	183.3 ^f
II-17b ²⁰	198.1 ^a	II-87 ⁴⁸	170.0 ^a
II-18a ^{154c}	196.1 ^a	II-88 ⁴⁸	169.7 ^a
II-18b ²⁰	199.0 ^a	II-89 ¹⁰⁵	184.5 ^g
II-18c ¹⁵⁷	185.9 ^b	II-90 ¹⁰⁹	164.9 ^g
II-19a ^{154c}	166.0 ^a	II-91 ^{151b}	168.5 ^b
II-19b ^{154c}	168.4 ^b	II-92 ^{151b}	168.0 ^a
II-20 ¹⁵⁸	175.3 ^a	II-93 ^{151b}	152.0 ^b
II-21 ^{154c}	167.8 ^a	II-95 ^{151b}	158.4 ^a
II-22 ^{45,152}	175.9, ^a 175.8 ^a	II-96a ¹⁶⁸	237.1 ^a
II-23 ^{154a}	183.8 ^a	II-96b ¹⁶⁸	239.9 ^d
II-24 ^{154a}	181.0 ^a	II-96c ¹⁶⁸	236.4 ^d
II-25 ^{154a}	182.7 ^a	II-96d ¹⁶⁸	235.0 ^f
II-26 ^{154a}	181.6 ^a	II-97a ¹⁶⁸	252.2 ^f
II-27 ^{154a}	181.1 ^a	II-97b ¹⁶⁸	249.7 ^b
II-28 ^{159a}	186.7 ^a	II-98a ¹⁶⁷	230.7 ^a
II-29 ^{159a}	175.2 ^a	II-98b ¹⁶⁹	236.7 ^d
II-30 ^{154d}	187.9 ^c	II-98c ¹⁶⁹	243.9 ^d
II-31 ^{154d}	190.6 ^c	II-98d ¹⁶⁹	238.6 ^a
II-32 ^{159b}	198.6 ^d	II-99 ²⁰	144.4 ^a
II-33 ^{159c}	167.6 ^b	II-100 ²⁰	146.2 ^a
II-34 ^{159c}	166.7 ^b	II-101 ²⁰	136.8 ^a
II-35 ^{159c}	157.2 ^b	II-102 ²⁰	132.9 ^a
II-36 ^{154b}	198.7 ^a	II-103 ²⁰	134.2 ^a
II-37 ^{154b}	161.3 ^a	II-104a ⁸⁷	142.2 ^a
II-38 ^{154b}	156.3 ^a	II-104b ⁸⁷	141.7 ^a
II-39 ^{159d}	184.9 ^e	II-104c ⁸⁷	141.8 ^a
II-44 ¹⁵⁷	196.0 ^d	II-104c ⁸⁷	141.7 ^a
II-45 ^{159c}	190.4 ^b	II-105 ²⁰	172.3 ^a
II-46 ^{159c}	190.0 ^b	II-106 ²⁰	174.1 ^a
II-47 ¹⁶¹	190.4 ^b	II-107 ¹⁵²	150.9 ^b
II-49 ^{154a}	184.7 ^d	II-108 ^{151b}	150.1 ^b
II-50a ¹⁶²	165.9 ^f		

^a CDCl₃. ^b CD₂Cl₂. ^c D[THF]. ^d C₆D₆. ^e Acetone-*d*₆. ^f CD₃CN. ^g DMSO-*d*₆. ^h CD₃OD.

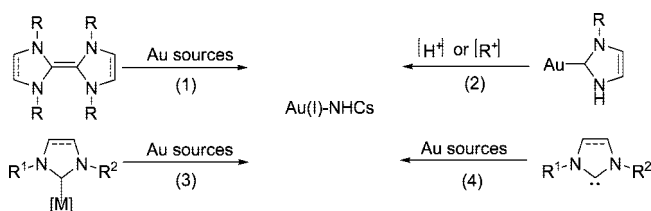
Scheme 25

As a typical example of the first method, the reaction of Au(PPh₃)Cl with electron-rich olefins at 100 °C produces Au(I)–NHC complexes.¹⁴⁰ This approach has been employed for a few cases, up to 2004.¹⁵⁰ In the second method, two sequential steps are involved. First, Au(I)–carbenate complexes are formed by the reaction of Au(I) sources with lithiated azoles; subsequently, the carbenate complexes are protonated or alkylated to produce Au(I)–NHC complexes. The known complexes are mainly those with thiazolyl NHC ligands. In the third method, some metal–NHCs can react with Au(I) sources to form Au(I)–NHCs.^{13,28} Ag(I)–NHCs are the most popular for transmetalation, though some group 6 and 7 metal–NHCs can also be utilized.^{64,151} While transmetalation is frequently carried out for five-membered ring NHCs, the situation for larger ring NHCs is yet to be clarified. In the fourth method, Au(I) sources react with free NHCs to form Au(I)–NHC complexes.^{18,29} The NHCs can be prepared *in situ* by reacting azolium salts with a strong base. Recently, there have been reports of Au(I)–NHC preparation by carboxylate or carbonate type weak base.^{27,152} Among these methods, the Ag–carbene transfer route comprises over 70% of the published results; the free carbene route constitutes around 20%.

Compared with Au(I)–NHC complexes, work on Au(III)–NHCs are few. There are three methods to prepare Au(III)–NHC complexes at present. The first is through the cyclization of Au(III)–coordinated isocyanide ligands.¹⁴¹ The second method is by oxidative addition of halogens to Au(I)–NHC compounds,^{20,152,153} The other is via transfer of NHCs from group 6 compounds to a Au(III) source.⁶⁴

3.3. Formation of Au(I)– and Au(III)–NHCs

In this section, we describe the preparation of Au(I)– and Au(III)–NHC complexes, their chemical and physical properties, and certain applications. The characterization of the complexes is mainly based on ¹H and ¹³C NMR and single-crystal XRD analyses. The ¹³C_{NHC} δ values (Table 2) for the Au(I)–NHC complexes are between 156.3 and 252.2 ppm, while they range from 132.9 to 174.1 ppm for the Au(III)–NHC complexes. Au(I)–NHCs are classified as neutral, ionic, multinuclear, and other types of bonding modes. A description of Au(III)–NHCs is given at the end.

3.3.1. Neutral [Au(NHC)L]

3.3.1.1. [Au(NHC)(halide)]/(pseudohalide). Scheme 26 lists [Au(NHC)L] type compounds **II-1–II-8**,¹⁵⁴ in which the NHC is imidazol-2-ylidene with symmetrical N-substituents and the L is halide or pseudohalide. These types of complexes are an important class of Au(I)–NHCs. They have been realized as robust starting materials for the preparation of compounds containing the Au(NHC) core.¹⁴⁷ They have also often been used either as catalysts or as catalyst precursors for many chemical transformation reactions. While most compounds in Scheme 26 were prepared through the

free NHCs, either isolated or generated *in situ*. Besides these methods, there is one example of synthesizing a Au(I)–NHC complex by intramolecular cyclization of Au(I)–isocyanide ligands.¹⁴¹

Scheme 26

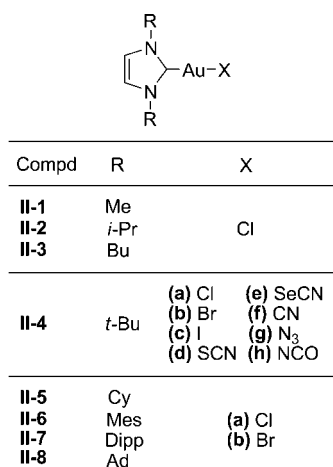

Ag–carbene transfer route, compounds **II-7a** and **II-8a** were prepared by the free carbene route.^{154c} An attempt to prepare **II-6a** through the free carbene route afforded the product in a low yield with [Au(NHC)₂]Cl and metallic gold as byproducts.^{154c} Both methods have been carried out for the preparations of compounds **II-2**, **II-3**, **II-4a**, and **II-5a**.^{20,154a,d} The Ag–carbene transfer route is more user-friendly and gives higher product yields. Although [Au(SMe₂)Cl] is the common Au(I) source, [Au(CO)Cl] is also known in preparing **II-4a** and **II-6a**.^{154d} In the Ag–carbene transfer route, reaction of [Au(SMe₂)Cl] with [Ag(NHC)(halide)] always produced [Au(NHC)Cl], despite the halide being bromide or iodide. In one case, however, contamination of bromide was reported.^{154a} The bromide and iodide complexes, **II-4b–II-8b**²⁰ and **II-4c**,^{154b} were generated through the reaction of [Au(NHC)Cl] with suitable alkali bromide or iodide salts. In the synthesis of [Au(NHC)(pseudohalide)] compounds **II-4d–h**,^{154b} silver pseudohalide salts were reacted with [Au(NHC)Cl]. Compounds **II-4a–II-8a** took part in some gold-catalyzed reactions.¹⁸

Scheme 27 lists [Au(NHC)Cl]-type compounds, where the NHCs are asymmetrically N,N'-disubstituted (**II-9–II-16**).^{22,23,44–46,49,87,155} Compounds in this category were prepared through the Ag–carbene transfer route; isolated Ag(I)–NHCs were used for compounds **II-9–II-15**, while Ag(I)–NHCs generated *in situ* were employed for compounds **II-16**. In the solid state, compound **II-14** assembles to form a dimer with a Au...Au distance of 3.204 Å and is luminous.⁴⁹ Compounds **II-9a** and **II-9b** have been used for gold-catalyzed reactions of hydrogenation of diethyl citraconate and diethyl benzylidensuccinate.^{49,156} Complex **II-9b**, with a terminal Si(OEt₃) and anchored on solid supports such as silica gel, ordered mesoporous silica, or delaminated zeolite, has been employed as a heterogeneous catalyst for hydrogenation and Suzuki-coupling reactions. These heterogenized complexes could be reused without losing their activity.^{155,156b} Compound **II-10** and **II-12** are known as catalysts for ROP reactions.^{44,45} Compound **II-13** showed antimicrobial activity.²³ Compounds **II-1**, **II-16a**, and **II-16b** demonstrated potencies to inhibit protein tyrosine phosphatases (PTPs);²² the details will be discussed in section 3.4.2.

Scheme 28 provides saturated NHC (imidazolidin-2-ylidene) Au(I) complexes **II-17** and **II-18**.^{20,154c,157} Compound **II-17a** was synthesized by the Ag–carbene transfer route and **II-18a** by the free carbene method. Both compounds were employed in catalytic reactions.¹⁸ Bromide complexes

Scheme 27

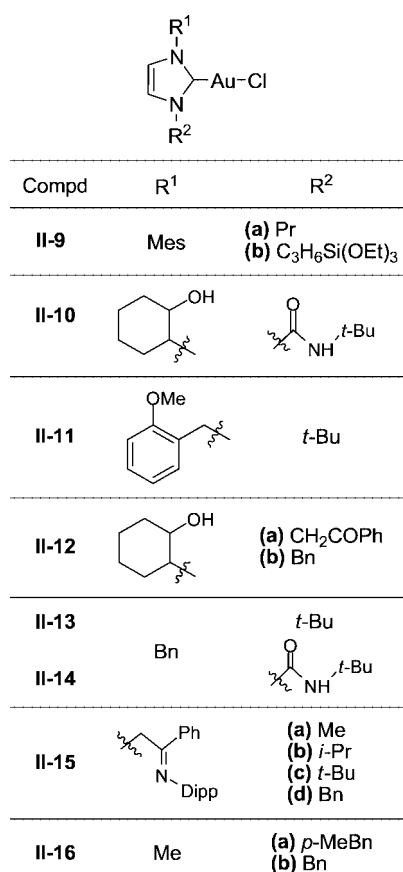

Scheme 28

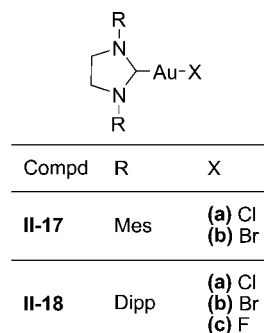

II-17b and **II-18b** were synthesized from their corresponding chloride compounds through halide metathesis reactions. The first isolable [Au(NHC)F] compound, **II-18c**,¹⁵⁷ was prepared through the sequential formation of [Au(NHC)(*Ot*-Bu)] (**II-44**, Scheme 32), followed by the reaction with Et₃N·HF. DFT calculations suggest that **II-18c** has a large partial negative charge on fluorine, and there is a slight lengthening of the Au–F bond, caused by F...H–C (CH₂Cl₂ solvent) hydrogen bonding.

Scheme 29 lists [Au(NHC)Cl]-type compounds, **II-19–II-22**,^{45,46,49,87,152,154c,155,158} that have different NHCs from those in Schemes 26–28. The Ag–carbene transfer route has been used to prepare **II-21** and **II-22** and the free carbene route for **II-19** and **II-20**. Compounds **II-19b–II-22** have been employed as catalysts.^{18,45,158}

3.3.1.2. [Au(NHC)(Ligand)]. Scheme 30 shows [Au(NHC)L]-type complexes, in which NHC represents symmetrically N-disubstituted imidazol-2-ylidene and L represents anionic ligands.^{64,154d,159} Analogous to the gold drug auranofin, compounds **II-23–II-28**, with a thioglucose

Scheme 29

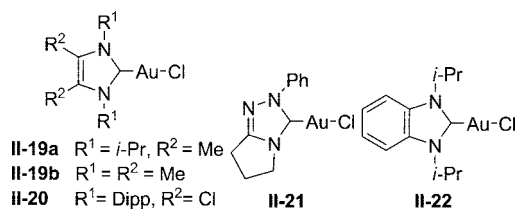

Scheme 30

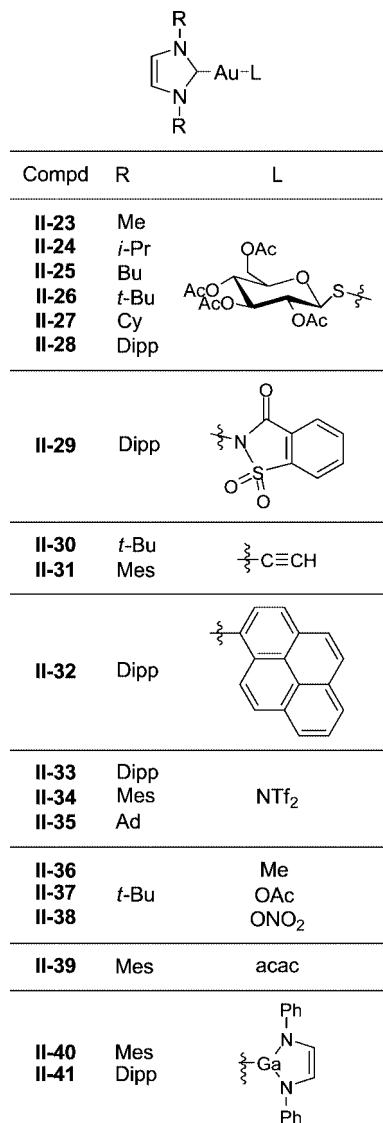

derivative as L, were prepared from the reaction of [Au(NHC)Cl] with HL in the presence of a base.^{154a,159a} As an analogue of the gold drug Solganol, compound **II-29** with a saccharin anion was obtained by reacting the corresponding [Au(NHC)Cl] with a sodium salt of saccharin in the presence of AgPF₆.^{159a} Acetylide-derived complexes **II-30** and **II-31** were synthesized by reacting [Au(NHC)Cl] compounds with [Mg(C≡CH)Cl].^{154d} Agostic Au⋯H interactions were found in the X-ray crystal structure of **II-30**. Similar to the luminous carbazolyl Au(I)–NHC compound,¹⁶⁰ pyrenyl anion was incorporated in the complex **II-32** through the reaction of **II-7b** with 1-pyrenylboronic acid in the presence of Cs₂CO₃.^{159b} This compound is projected as a potential photodevice and photosensor. Reacting [Au(NHC)Cl] with Ag[N(SO₂CF₃)₂] (denoted as Ag(NTf₂)) produced **II-33–II-**

Scheme 31

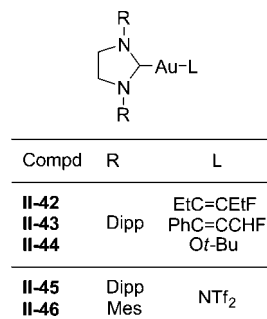

35 with NTf₂ as L.^{159c} These complexes were used for gold-catalyzed reactions.^{18,159c} Compounds **II-36–II-39**^{154b,159d} were synthesized by the reaction of [Au(NHC)Cl] with Mg(CH₃)₂, AgOAc, AgNO₃, or Tl(acac), respectively. Compounds **II-40** and **II-41** were prepared by reacting [Au(NHC)Cl] with anionic Ga(I) heterocycle.⁶⁴

Scheme 31 provides [Au(NHC)L] type complexes with saturated NHCs.^{157,159c} Two interesting [Au(NHC)(fluorovinyl)] compounds, **II-42** and **II-43**, were obtained by reacting the [Au(NHC)F] compound **II-18c** with unactivated alkynes of 3-hexyne and 1-phenyl-1-propyne, respectively.¹⁵⁸ In this reaction, the alkyne inserted into a Au–F bond and formed a C–F bond. This reaction could be reversible. Compound **II-44** with O*t*-Bu as L was obtained through reaction of the corresponding [Au(NHC)Cl] with NaO*t*-Bu.^{159d} The preparation of **II-45** and **II-46**^{159c} with NTf₂ as L is similar to those of **II-33** and **II-34** with unsaturated NHCs. These complexes are very useful in some gold-catalyzed organic reactions.^{18,159c}

For the neutral [Au(NHC)L]-type complexes described in the section 3.3.1, the ¹³C_{NHC} δ values for the saturated NHC complexes fall between 185.0 and 199.0 ppm, more downfield compared with those of the unsaturated NHC complexes at 160–182 ppm.

3.3.2. Ionic [Au(NHC)L][Anion]

3.3.2.1. [Au(NHC)(Ligand)][Anion]. Schemes 32 and 33 show [Au(NHC)(ligand)][anion] type ionic compounds, in which the NHCs are imidazol-2-ylidenes except one imidazolidin-2-ylidene, and the non-NHC ligand L is neutral. An interesting route to synthesize Au(I)–NHC **II-48** along with proposed mechanism is shown in Scheme 32.¹⁶¹ A cationic imidazole complex with Mn attached to one N atom was deprotonated with KO*t*-Bu. The resulting complex transformed immediately to the carbenate complex, showing that the Mn ion had a preference for C-binding over N-binding. A subsequent reaction with a mild proton source, NH₄PF₆, formed a Mn(I)–NHC complex, which upon further deprotonation by KOH followed by reaction with [Au(PPh₃)Cl] produced a heterometallic complex. This complex transformed into an isomer **II-47**, again displaying a different kind of bond preference. On combination of **II-47** with HClO₄, **II-48** was generated.

Compound **II-49**, with a strong coordinating ligand PPh₃, was synthesized simply by reacting a [Au(NHC)Cl]-type compound with PPh₃ in the presence of KPF₆.^{154a} However, an unexpected result was observed when a [Au(NHC)Cl]-type compound in CH₂Cl₂ was reacted with AgBF₄ in EtOH. On adding PPh₃, homoleptic [Au(NHC)₂]⁺ and [Au(PPh₃)₂]⁺ type complexes were produced instead of the expected [Au(NHC)(PPh₃)]⁺-type compound.¹⁴⁷ The discrepancy in the outcomes could be attributed to the difference in the use

Scheme 32

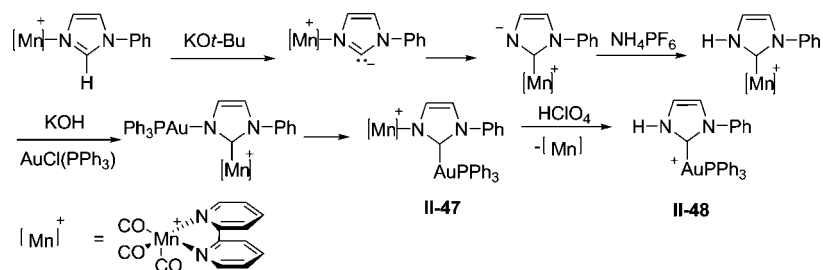

Scheme 33

Compd	R ¹	R ²	L	Anion
II-49	<i>t</i> -Bu	<i>t</i> -Bu	PPh ₃	PF ₆ ⁻
II-50	Dipp	Dipp	CH ₃ CN	(a)BF ₄ ⁻ (b)PF ₆ ⁻
II-51	Mes	Mes	PPh ₃ CHPh	BF ₄ ⁻
II-52	Mes	Mes	2,4,6-(MeO) ₃	SbF ₆ ⁻
II-53	Me	Et	C ₆ H ₂ CN	
II-54	<i>t</i> -Bu	<i>t</i> -Bu	C ₆ H ₂ CN	
II-55	Dipp	Dipp	NCPH	SbF ₆ ⁻

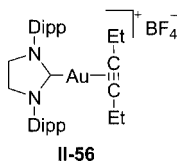

of AgBF₄ and KPF₆ as Cl scavengers. Possibly the good Cl scavenger, AgBF₄, promoted the formation of thermodynamically more stable complexes. Compounds **II-50a** and **II-50b** with acetonitrile ligand were prepared by the respective reaction of [Au(NHC)Cl] with AgBF₄ and AgPF₆ in the coordinating solvent acetonitrile.¹⁶² Compound **II-50a** was employed as a catalyst to activate ethyl diazoacetate in carbene transfer reactions. A [Au(NHC)(acac)]-type compound **II-39** (Scheme 31) was allowed to react with [PPh₃CH₂Ph][BF₄] to prepare phosphorus ylide-derivatized **II-51**.^{159d} In this reaction, the anionic acac ligand behaves as a weak base to deprotonate the ylide precursor phosphonium salt. Compound **II-51** was used to study phosphine dissociation in the gas phase by mass spectrometry. A dissociation energy of 51.7 kcal/mol was determined. DFT calculations using the M06-L functional gave a dissociation energy 58.8 kcal/mol, comparable to the experimental result. Compounds **II-52–II-54** were prepared from the corresponding [Au(NHC)Cl]-type compounds with 2,4,6-trimethoxybenzotrile and AgSbF₆, compound **II-55** was obtained by reacting **II-7** with PhCN and AgSbF₆. Compounds **II-52–II-55** were used in gold-catalyzed reactions.¹⁶³ A saturated NHC complex **II-56** with a Au–alkyne moiety was synthesized by treating the corresponding [Au(NHC)Cl] with AgBF₄ and 3-hexyne.¹⁵⁸ The ¹³C_{NHC} δ values for the unsaturated complexes **II-47–II-55** range between 165.7 and 190.4 ppm, while that for the saturated complex **II-56** is 199.2 ppm.

Scheme 34

Compd	R ¹ = R ²	Anion	
II-57	Me	Br	
II-58	Et		
II-59	Pr		
II-60	<i>i</i> -Pr	Cl	
II-61	Bu		
II-62	Cy		
II-63	<i>t</i> -Bu		
Compd	R ¹	R ²	Anion
II-64	Me	Et	PF ₆ ⁻
II-65	Me	CH ₂ Ment	Cl
II-66		C ₆ H ₄ Fc	BF ₄ ⁻
II-67	Me	CH ₂ Py	BF ₄ ⁻
II-68	Me		PF ₆ ⁻
II-69	Me	Py	BF ₄ ⁻

II-70	R ¹ = <i>i</i> -Pr, R ² = <i>t</i> -Bu	PF ₆ ⁻
II-71	R ¹ = R ² = <i>t</i> -Bu	

II-72		PF ₆ ⁻
II-73		

Compd	R	n
II-74	Nap	2
II-75		3
II-76	Ant	2
II-77		3

3.3.2.2. [Au(NHC)₂][Anion]. Scheme 34 shows [Au(NHC)₂]-[anion]-type compounds where the NHCs are imidazol-2-ylidene and benzimidazol-2-ylidene. Using the free carbene method, direct reaction of [Au(SMe₂)X] (X = Br or Cl) with two equivalents of the appropriate imidazolium salt in the presence of a base, lithium hexamethyl disilazide (LiHMDS), produced compounds **II-57–II-64**. These complexes showed antimitochondrial activity.¹⁶⁴ Similarly, compound **II-65** was obtained using [Au(PEt₃)Cl] as Au(I) source and *t*-BuLi as base.¹⁰ Alternatively, **II-65–II-72** were synthesized by the Ag–carbene transfer route, reacting two equivalents of the corresponding [Ag(NHC)Cl] compounds with [Au(SMe₂)Cl].^{10,48,84,165} The free carbene and the Ag–carbene transfer routes were compared for compounds **II-65** and **II-72**; *in situ* generated free carbenes gave better yields. In these examples, the Au(I) precursor was [Au(PEt₃)Cl] rather than the commonly used [Au(SMe₂)Cl]. Compounds **II-65** and **II-72** were employed as catalysts in diboration of terminal alkenes.¹⁰ Compound **II-73** was prepared by reacting **II-22** with the corresponding imidazolium tetrafluoroborate with weak base K₂CO₃.¹⁵² Auro-crown-ether complexes **II-74–II-77** were prepared from their corresponding Ag(I)–NHCs.⁹⁷

Scheme 35

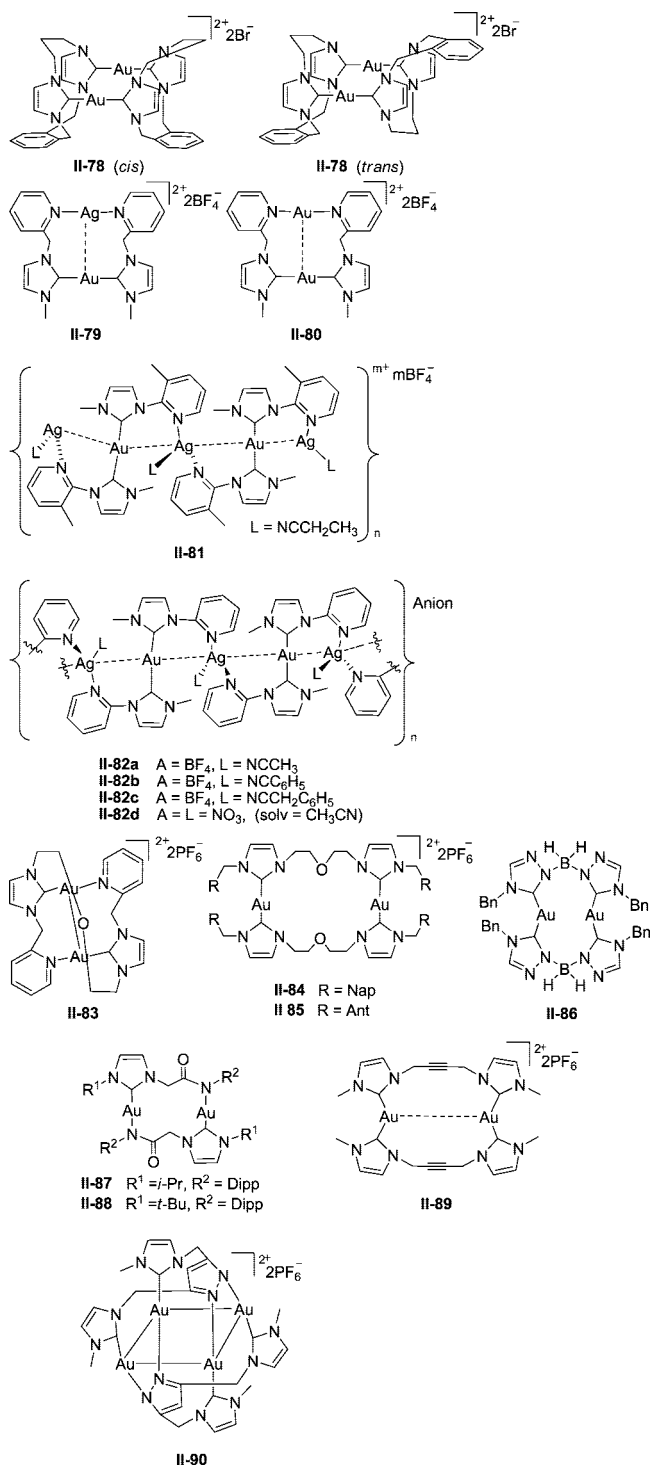

The $[\text{Au}(\text{NHC})_2][\text{anion}]$ -type complexes often have lower $^{13}\text{C}_{\text{NHC}}$ chemical shifts than those of the neutral $[\text{Au}(\text{NHC})(\text{halide})]$ -type compounds. This generalization is apparent when we compare the identical sets of NHCs in **II-60–II-63** (ca. 180 ppm) and **II-2–II-4** (ca. 168 ppm). Thus $^{13}\text{C}_{\text{NHC}}$ δ values could provide a means to differentiate between the two types of compounds.

3.3.3. Multinuclear Au(I)–NHCs

Scheme 35 shows Au(I)–NHCs with nuclearity of two or more, including heteronuclear compounds. The NHCs listed in this category are imidazol-2-ylidenes except one

Scheme 36

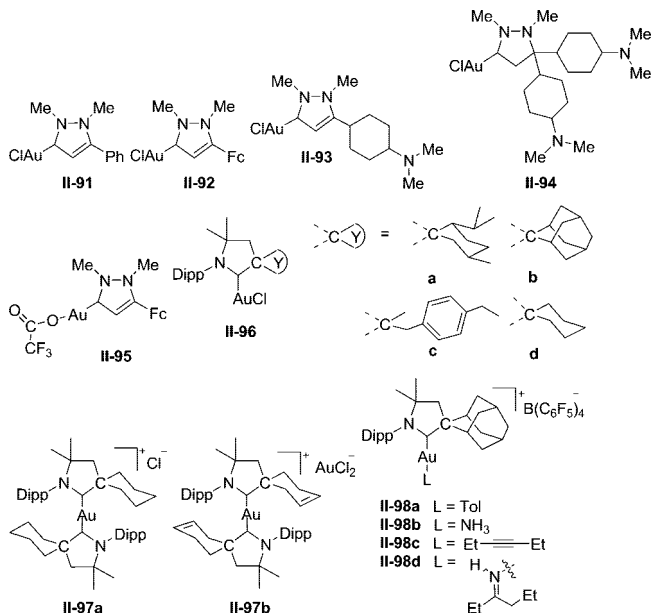

triazol-5-ylidene. Most of these complexes show Au(I)···Au(I)/Ag(I) interactions and exhibit luminescence properties.

Dinuclear compounds **II-78** were obtained by directly reacting $[\text{Au}(\text{SMe}_2)\text{Cl}]$ with the corresponding cyclo-bis-imidazolium salt in the presence of mild base $\text{Na}(\text{OAc})$.²⁷ Complex **II-67** (Scheme 35) having two pendant-picolyl arms was allowed to react with AgBF_4 to produce a heterodinuclear compound **II-79** and with $\text{Au}(\text{tht})\text{Cl}$ (see section) to generate a digold compound **II-80**.^{165b} $[\text{Au}(\text{NHC})_2]^+$ -type complexes **II-68** and **II-69** (Scheme 34), having two pyridyl side arms, were reacted with AgBF_4 to yield polyheteronuclear compounds **II-81** and **II-82**, respectively.

Dinuclear compounds **II-83–II-89** were prepared by the Ag–carbene transfer route, in which the Ag(I)–NHCs were generated *in situ* for **II-83**¹¹³ and isolated for **II-84–II-89**.^{48,106,109,166}

As in the Ag(I) complexes **I-10** and **I-11**, a difference in the amido-N-substituents (*t*Bu vs Dipp) is responsible for producing mononuclear compounds **II-70** and **II-71** and dinuclear compounds **II-87** and **II-88**. Interestingly, the Au···Au interaction in **II-87** and **II-88** is much weaker than the Ag···Ag interaction in **I-10** and **I-11**. The tetranuclear compound **II-90** was obtained from its corresponding Ag(I)–NHC.

3.3.4. Other Classes of Au(I)–NHCs

Scheme 36 shows compounds with NHCs other than those in Schemes 26–35. Transfer of pyrazolin-3-ylidene and pyrazolidin-3-ylidene carbene ligands from chromium to a Au(I) source produced the abnormal Au(I)–NHC compounds **II-91–II-95**.^{151b}

Bertrand's group has developed a new class of unusual metal–NHC complexes, which are very useful catalysts in many organic transformations.¹⁶⁷ This type of sterically demanding carbene, known as cyclic (alkyl)(amino)carbene (CAAC), has a strong σ -donor character. Reaction of free CAACs with $[\text{Au}(\text{SMe}_2)\text{Cl}]$ readily produced neutral $[\text{Au}(\text{CAAC})\text{Cl}]$ type NHC complexes **II-96**.¹⁶⁸ These compounds are slightly unstable toward light. Their $^{13}\text{C}_{\text{NHC}}$ δ values are shifted downfield to 235–240 ppm. Recrystallization of compound **II-96d** in CD_2Cl_2 over several days led to a $[\text{Au}(\text{CAAC})_2]\text{Cl}$ -type complex **II-97a**, a product obtained

Scheme 37

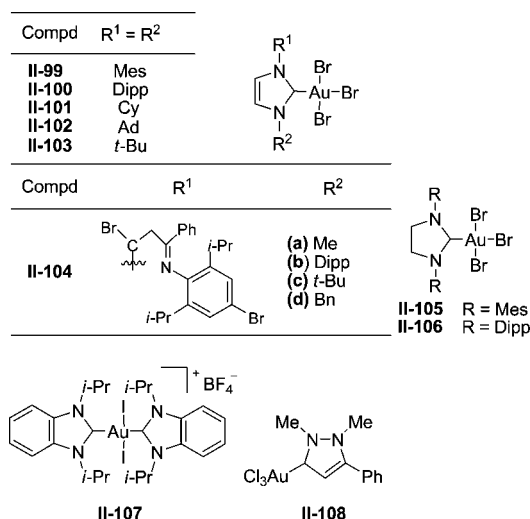

from the disproportionation of $[\text{Au}(\text{CAAC})_2][\text{AuCl}_2]$ to $[\text{Au}(\text{CAAC})_2]\text{Cl}$ and AuCl .¹⁶⁸ Ionic $[\text{Au}(\text{CAAC})_2][\text{AuCl}_2]$ -type compound **II-97b** was generated via the free CAAC route. Also similar to the known $\text{Ag}(\text{I})\text{-NHC}$ examples, disproportionation reaction of $[\text{Au}(\text{CAAC})_2][\text{AuCl}_2]$ to $[\text{Au}(\text{CAAC})_2]\text{Cl}$ and AuCl could lead to **II-97a**. The steric hindrance and the flexibility of the substituents at the carbon atom next to the carbene carbon affect the types of $\text{Au}(\text{I})\text{-CAAC}$ complexes produced in a reaction. Bulky and rigid substituents favor the isolation of neutral $[\text{Au}(\text{CAAC})\text{Cl}]$ -type compounds, while smaller cyclohexyl and cyclohexylene groups give rise to ionic compounds. The $^{13}\text{C}_{\text{NHC}}$ δ values of these $[\text{Au}(\text{CAAC})_2]$ -type compounds (ca. 250 ppm) are 10–14 ppm downfield relative to those of the $[\text{Au}(\text{CAAC})]$ -type complexes.

Several interesting cationic carbene complexes of the type $[\text{Au}(\text{CAAC})\text{L}][\text{anion}]$, where L is a neutral ligand other than CAAC, were isolated.^{167,169} Ionic compound **II-98a** with a L of η^2 -toluene was obtained through the reaction of the corresponding $[\text{Au}(\text{CAAC})\text{Cl}]$ with a halide scavenger in toluene.¹⁶⁹ It appears to be a very reactive and useful starting material for the synthesis of carbene complexes containing the $\text{Au}(\text{CAAC})$ core. Reaction of this compound with excess NH_3 readily afforded compound **II-98b** with a coordinated NH_3 ligand. Similarly, reaction of compound **II-98a** with 3-hexyne gave **II-98c** with an alkyne ligand. Reaction of **II-98b** with excess 3-hexyne produced imino-coordinated $\text{Au}(\text{I})\text{-CAAC}$ compound **II-98d**. Compound **II-98a** is also an excellent catalyst for the cross-coupling of enamines and terminal alkynes to form allenes.¹⁶⁸ A reaction pathway involving $[\text{Au}(\text{carbene})(\text{vinylidene})]$ intermediates has been proposed.

3.3.5. $\text{Au}(\text{III})\text{-NHC}$ Complexes

As shown in Scheme 37, examples of $\text{Au}(\text{III})\text{-NHC}$ complexes are very limited. Compounds **II-99–II-106** were prepared through oxidation of the corresponding $[\text{Au}(\text{NHC})\text{Br}]$ complexes with Br_2 ,^{20,155} and a luminous compound **II-107** was obtained by oxidizing a $[\text{Au}(\text{NHC})_2]^+$ type compound **II-73** with I_2 .¹⁵² Interestingly, formation of compounds **II-104** appeared to go through a long-range 1,7-bromination, which occurred at two different carbon sites spatially separated by ca. 6.4 Å, across the imino-functionalized side arm of the NHC ligand.⁸⁷ Attempts to prepare

$\text{Au}(\text{III})\text{-NHC}$ s by direct reaction of $\text{Au}(\text{III})$ sources with free carbene resulted in mostly metallic Au along with decomposition of the carbene and formation of $\text{Au}(\text{I})\text{-NHC}$ s.^{20,152} Compound **II-108** was synthesized through the transfer of pyrazolin-3-ylidene from $[\text{Cr}(\text{NHC})(\text{CO})_5]$ to HAuCl_4 .^{151b} Surprisingly, $\text{Au}(\text{III})$ compound **II-108** and its HCl adduct were both obtained when HAuCl_4 was employed as the carbene acceptor. The $^{13}\text{C}_{\text{NHC}}$ δ values for the unsaturated NHC $\text{Au}(\text{III})$ complexes are between 132.9 and 150.9 ppm, and those for the saturated complexes appear at ca. 173 ppm. These values are ca. 30 ppm upfield compared with those of the corresponding $\text{Au}(\text{I})\text{-NHC}$ s, attributed to an increase in the acidity of $\text{Au}(\text{III})$ moieties.^{20,152}

3.4. Applications

3.4.1. $\text{Au}(\text{I})\text{-}$ and $\text{Au}(\text{III})\text{-NHC}$ s in Catalysis

There is a considerable surge of using gold compounds to catalyze organic transformations, popularly called the Gold Rush in the past few years. Although simple Au salts like AuCl or NaAuCl_4 are known to catalyze many organic reactions, the lack of a stabilizing ligand usually causes spontaneous reduction of $\text{Au}(\text{I})$ or $\text{Au}(\text{III})$ to inactive metallic gold. This renders low turnovers of catalytic performance and hampers the growth of homogeneous catalysis. Phosphine ligand supported Au compounds suppress the formation of metallic gold. Indeed, higher catalytic efficiency could be obtained with $\text{Au}(\text{I})\text{-phosphine}$ complexes as catalysts. A number of reviews regarding the insight and development of Au-catalyzed reactions have been published.^{17,170}

Since the first $\text{Au}(\text{I})\text{-NHC}$ -catalyzed hydration of 3-hexyne was reported in 2003,¹⁴⁸ the role of $\text{Au}(\text{I})\text{-NHC}$ s in organic transformations has increased steadily. Similar to the $\text{Au}(\text{I})\text{-phosphine}$ complexes,^{19a,b} $\text{Au}(\text{I})\text{-NHC}$ complexes have shown good catalytic activities toward activation of alkynes or alkenes to nucleophiles, leading to cyclizations, cycloadditions, or heteroatom additions. In general, the catalytically active $\text{Au}(\text{I})\text{-NHC}$ moieties can be generated *in situ* from treatment of $[\text{Au}(\text{NHC})(\text{halide})]$ with silver salt. The organic reactions promoted by $\text{Au}(\text{I})\text{-}$ and $\text{Au}(\text{III})\text{-NHC}$ complexes, shown in Scheme 38, exhibit remarkable activities.¹⁸ It is worthy to note that a few $\text{Au}(\text{III})\text{-NHC}$ complexes can also promote reactions of olefin polymerization and heteroatom addition to alkynes.^{20,171} In many reactions, $\text{Au}(\text{I})\text{-}$ and $\text{Au}(\text{III})\text{-NHC}$ complexes usually show comparable or superior efficiency compared with the $\text{Au}\text{-phosphine}$ or $\text{Au}\text{-pyridine}$ complexes.¹⁷² However, in limited cases, $\text{Au}(\text{I})\text{-NHC}$ complexes with lower catalytic reactivities are known.¹⁷³ In the last two years, $\text{Au}(\text{I})\text{-}$ and $\text{Au}(\text{III})\text{-NHC}$ -catalyzed organic reactions have been partly reviewed.^{19c–j,170a,b} Very recently, Marion and Nolan specifically reviewed the $\text{Au}(\text{I})\text{-}$ and $\text{Au}(\text{III})\text{-NHC}$ complex catalyzed reactions.¹⁸ Reactions summarized in these reviews are given in Scheme 38. We herein focus on the new results, which have appeared after that review.

Scheme 39 shows the use of $[\text{Au}(\text{NHC})\text{Cl}]$ complex **II-7a** as a highly regio- and stereoselective catalyst in intermolecular hydroalkoxylation¹⁷⁴ and hydroamination¹⁷⁵ at either of the allene $\text{C}=\text{C}$ bonds. Particularly, **II-7a** in combination with AgOTf as a catalyst has a better conversion than that with AgBF_4 . Moreover, there is a contrasting regioselectivity between the hydroalkoxylation and hydroamination of differently 1,3-disubstituted allenes; while the alcohol preferentially attacks at the less substituted

Scheme 38

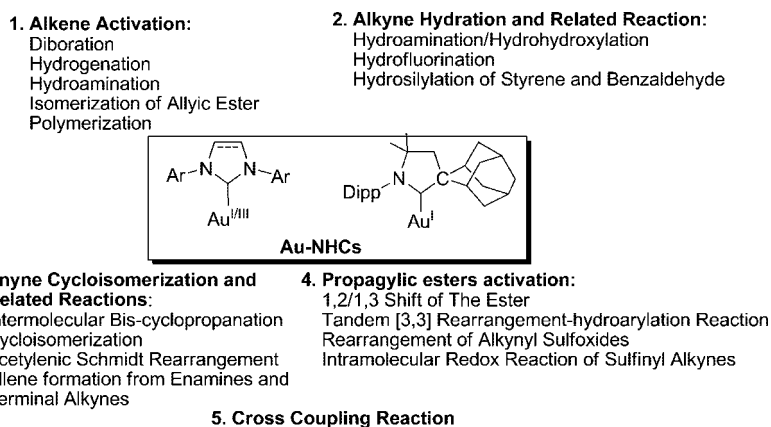

Scheme 39

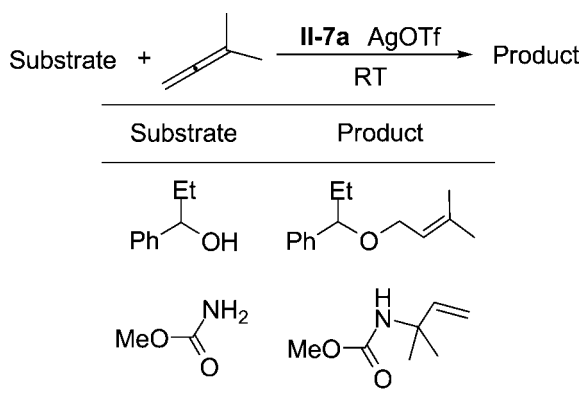

Scheme 40

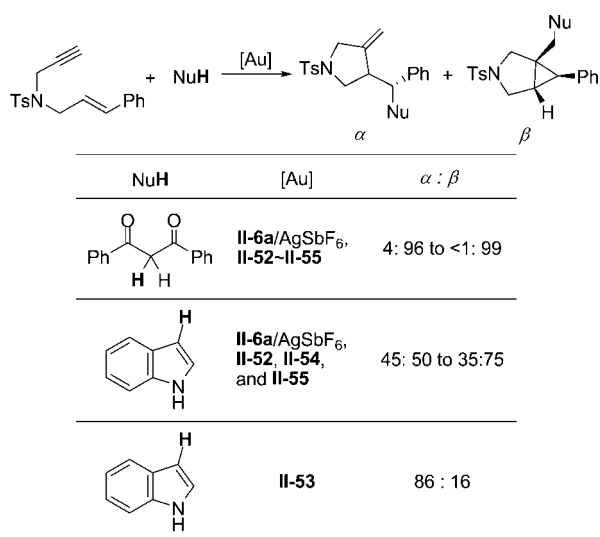

terminus, the amine favors the addition to the more electron-rich terminus.

Scheme 40 shows the addition of carbon nucleophiles, including indoles and 1,3-dicarbonyl compounds, to 1,6-enynes catalyzed by some Au(I)-NHC complexes.¹⁶³ When Au(I)-NHC complexes **II-6a** and **II-52-II-55** were employed as catalysts and 1,3-dicarbonyl compounds as nucleophile, β -type products were favored. With indole as nucleophile, while **II-6a**, **II-52**, **II-54**, and **II-55** favored β -type products, the less bulky N-substituted **II-53** favored α -type products.

Scheme 41 shows several organic transformations catalyzed by complex **II-33**. 1,3-Diene derivatives were the dominating products through 1,2-acyloxy migration from propargylic pivalates (eq 1).¹⁷² Complex **II-33** promoted the [4 + 2] annulation of the "all carbon 1,4-dipoles" 1-(1-alkynyl)cyclopropyl ketone to give a series of furans (eq 2).¹⁷⁶ Similarly, functionalized bicyclic compounds were efficiently synthesized using **II-33** as a catalyst in a lower loading than that using AuCl₃ (eq 3).¹⁷⁷

Scheme 42 shows Au(I)-CAAC-catalyzed hydroamination of alkynes and allenes with NH₃.¹⁶⁹ The reaction of alkynes with NH₃, catalyzed by **II-98a** gave moderate to high yields of cyclic and acyclic hydroamination products (entry 1 and 2). Reaction of allenes with NH₃, catalyzed by **II-98a**, gave high yields of allylamine. The selectivity of mono-, di-, and triallylamine could be controlled by changing the ratio of the substrate and NH₃ (Scheme 42, entries 3–5).

3.4.2. Au(I)-NHCs in Medicine

The medicinal properties of Au(I)-phosphine complexes have long been realized.¹⁷⁸ For example, auranofin, a well-known antiarthritis drug, is a Au(I) complex with a triethylphosphine and a ligand derivatized from thioglucose. Recently, compounds of the auranofin family have been found to initiate apoptosis, that is, cell death by a mitochondrial pathway, through selective inhibition of mitochondrial thioredoxin reductase.¹⁷⁹ Many Au(I)-phosphine complexes were found to affect the normal functioning of mitochondria; however only the ionic Au(I)-phosphine complexes with optimized lipophilicity selectively affected the tumor cells.¹⁸⁰

The similarity between phosphine and NHC and the ease of systematic modification of NHCs from imidazolium salts have rendered Au(I)-NHCs attractive in medicinal applications. In 2007, Berners-Price and Barnard reviewed the medicinal applications of Au(I)-NHC complexes.²¹ They summarized that a family of ionic cyclophane and cyclophane-like dinuclear Au(I)-NHCs were able to induce a mitochondrial permeability transition via pore formation on the inner membrane.¹⁸¹ This process was Ca²⁺ sensitive, so without Ca²⁺, these Au(I)-NHCs were either inactive or substantially less active. Ionic [Au(NHC)₂]⁺-type compounds (**II-57**, **II-60-II-64**, Scheme 34) were also mentioned to permeate the mitochondrial inner membrane of isolated rat liver cells.^{164a} A correlation was seen between the compounds' lipophilicity and their mitochondrial membrane permeation. Neutral [Au(NHC)L] type compounds **II-23-II-28** (Scheme 30), analogues of [Au(PEt₃)Cl] and auranofin,

Scheme 41

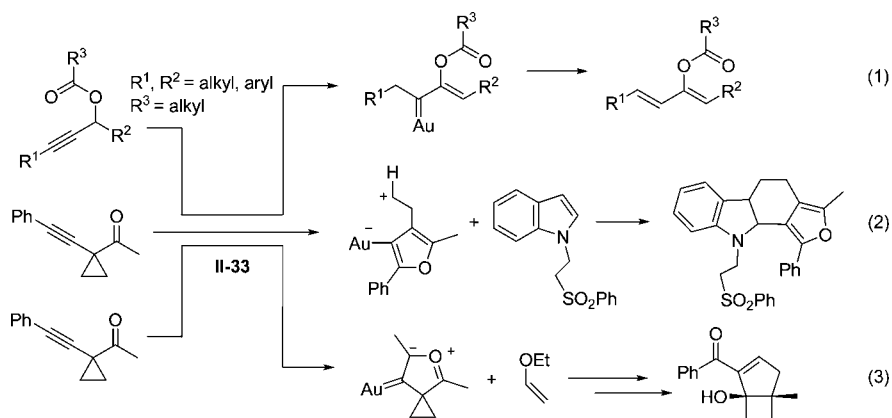

Scheme 42

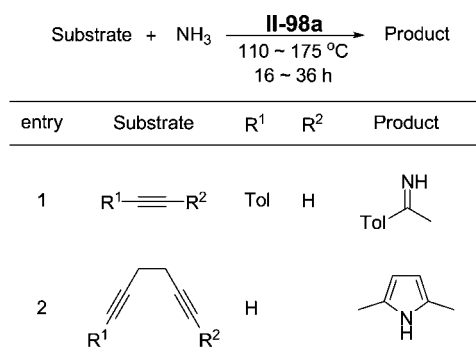

entry	substrate	NH ₃ /substrate	Product ratio ^a
3		1.4/1	1/ 4.3/ 3.7
4		40/1	6.2/ 1/-
5		1/4.5	1/ 6/ 73

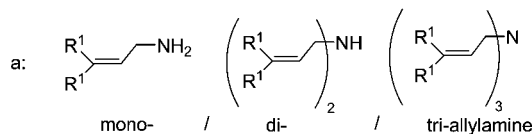

have also been discussed. Although these compounds demonstrate different lipophilicities with different *N*-alkyl substituents, their applications in mitochondrial function have not been reported.^{154a,159a}

Recently the ionic [Au(NHC)₂]Cl-type compound **II-60** (Scheme 34) and a neutral compound **II-2** (Scheme 26) were tested for anticarcinogenic activities in three different liver cell lines, of which one was cancerous.¹⁸² Compound **II-60**, with an optimal range of lipophilicity, selectively penetrated the cancerous cells and accumulated in the mitochondria. On the other hand, **II-2** induced nonselective cell death in all the three cell lines. The authors proposed that the cancerous cells have a higher mitochondrial membrane potential ($\Delta\Psi_m$). This results in a selective accumulation of the ionic compound into the mitochondria of cancerous cells. This accumulation depolarizes the $\Delta\Psi_m$ and diminishes the ATP pool, resulting in the activation of apoptosis via the mitochondrial pathway.

Mitochondria-targeted chemotherapeutic cationic Au(I)–NHC complexes that possess selective toxicity to breast cancer cells have been designed.^{164b} [Au(NHC)₂][halide]-type com-

plexes, NHCs being imidazol-2-ylidene with symmetric simple *N*-methyl, ethyl, propyl, and *i*-propyl-substituents (**II-57**–**II-60**, Scheme 34), were found to induce apoptosis only in cancer cells. A two-step sequential substitution of the ligands in **II-57** and **II-60** by cysteine and selenocysteine has been proposed to explain the process.

Ghosh's and Panda's groups have tested the anticancer and antimicrobial activities of metal–NHCs.²³ A neutral [Au(NHC)Cl], **II-13** (Scheme 27), was found inactive toward human cervical cancer, breast cancer, and colon cancer. However, this compound showed bactericidal activity toward *Bacillus subtilis* and was twice as potent as the Ag analogue. Mulliken and natural charge analyses of **II-13** and its silver analogue show that the Au(I) complex has a higher electron density at the metal center, which probably enhances its bactericidal activity.

Cytotoxicity studies of a heterobimetallic Au(I)–NHC with ferrocenyl ligands (**II-66**, Scheme 34) showed that the cytotoxicity assays were sensitive to the Jurkat T leukemia and the MCF-7 breast cancer cell lines.^{165a} However, the role of the ferrocenyl group was uncertain.

In addition, neutral [Au(NHC)Cl]-type compounds were also tested for their ability to inhibit the cysteine-dependent protein tyrosine phosphatase (PTP) activity that were known to have implications in several disease states.²² Au(I)–NHCs **II-1** and **II-16a,b** (Schemes 26 and 27) inhibited PTP activity in Jurkat T leukemia cells with some selectivity. These compounds also inhibited phosphatase activity in primary mouse thymocytes. The affinity of Au(I) for thiolate ligands suggested an inhibition occurring through complexation with the cysteine residue. Further structure–activity relationship studies may lead to better therapeutically relevant, membrane-permeable PTP-selective Au(I) inhibitors.

4. Cu(I)– and Cu(II)–NHCs

4.1. Historical Background

The chemistry of Cu(I)– and Cu(II)–NHC complexes has been relatively less studied compared with the other coinage metal–NHCs, although the first Cu(I)–NHC complex was reported in 1993 by Arduengo.³⁶ Two reports regarding the synthesis of the neutral [Cu(NHC)(halide)]-type complexes were provided by Raubenheimer and co-workers in 1994 and 1995.^{183,184} Boehme and Frenking reported theoretical calculations on the nature of the Cu–NHC bond in 1998.¹⁸⁵ Danopoulos and co-workers presented the first use of Cu₂O as both base and Cu source to make Cu(I)–NHCs in 2001.¹⁸⁶

Table 3. $^{13}\text{C}_{\text{NHC}}$ δ Values for Cu(I)–NHC Complexes

compd	(ppm)	compd	δ , ppm
III-1a ³⁶	178.2 ^c	III-30a ²²⁶	182.6 ^d
III-1b ²⁰⁰	178.8 ^e	III-30b ²²⁷	204.8 ^d
III-1c ²⁰⁰	178.8 ^e	III-30c ²²⁷	180.9 ^d
III-1e ²⁰¹	177.4 ^a	III-31a ²²⁶	186.5 ^d
III-1f ²⁰¹	178.4 ^a	III-31b ²²⁷	182.8 ^d
III-1g ²⁰⁰	171.2 ^e	III-31c ²²⁷	184.7 ^d
III-1h ²⁰⁰	171.7 ^e	III-31d ²²⁸	186.3 ^d
III-1i ²⁰⁰	169.9 ^e	III-32a ²²⁸	182.2 ^d
III-1j ²⁰⁰	169.8 ^e	III-32b ²³¹	204.7 ^d
III-1k ²⁰⁰	173.8 ^e	III-32c ²³¹	181.8 ^d
III-1l ²⁰⁰	174.2 ^e	III-33a ²²⁸	205 ^d
III-1m ²⁰⁰	201.4 ^e	III-33b ²³¹	205 ^d
III-1n ²⁰⁰	199.8 ^e	III-34a ²²⁸	182.8 ^d
III-1o ²⁰⁰	201.3 ^e	III-34b ²³¹	205.2 ^d
III-1p ²⁰⁰	201.4 ^e	III-34c ²³¹	181.1 ^d
III-2 ²⁰²	198.9 ^a	III-35a ²²⁹	182.8 ^d
III-6a ¹⁹⁰	180.2 ^e	III-35b ²²⁹	200.6 ^g
III-6b ²¹²	181.2 ^e	III-36a ²²⁹	183.3 ^d
III-6c ²¹²	182.8 ^a	III-36b ²²⁹	215.6 ^g
III-7a ²⁰⁹	178.7 ^a	III-37a ²²⁸	184.2 ^d
III-7b ²⁰⁸	174.2 ^e	III-38 ²²⁸	163.3 ^d
III-8 ²¹⁰	172.1 ^a	III-39 ²⁴⁹	177.9 ^d
III-9 ²⁰⁸	202.8 ^a	III-40b ²³²	179.1 ^d
III-10a ²¹¹	202.6 ^a	III-41a ⁶⁴	181.2 ^d
III-10b ²⁰⁹	202.8 ^a	III-41b ⁶⁴	182.7 ^d
III-11a ²⁰²	194.7 ^a	III-41c ⁶⁴	173.7 ^d
III-11b ²⁰²	195.1 ^a	III-42 ²³³	164.0 ^d
III-12 ²¹⁴	165 ^a	III-43 ²³⁰	204.7 ^b
III-15 ⁶²	205.3 ^a	III-44 ²³⁴	185.3 ^c
III-16b ¹⁹⁵	174.2 ^a	III-45 ²³⁵	188.3 ^a
III-17a ¹⁸³	198.3 ^b	III-46a ²¹⁰	183.6 ^d
III-17b ¹⁸⁴	203.5 ^b	III-46b ²¹⁰	184.9 ^d
III-17c ¹⁸⁴	216.3 ^b	III-46c ²¹⁰	184.0 ^d
III-17d ¹⁸⁴	177 ^b	III-46d ²¹⁰	184.7 ^d
III-17f ¹⁸⁴	202.5 ^b	III-46e ²¹⁰	191.6 ^d
III-17g ¹⁸⁴	205 ^b	III-46f ²¹⁰	184.0 ^d
III-17h ¹⁸⁴	214.3 ^b	III-46g ²¹⁰	184.8 ^d
III-18a ²¹⁵	184.4 ^d	III-48a ²³⁶	187.0 ^f
III-18b ²²³	177.5 ^d	III-48b ²³⁶	189.7 ^f
III-19 ²¹⁵	186.9 ^d	III-53a ²³⁸	178.6 ^a
III-20a ²¹⁷	187.2 ^d	III-53b ²³⁸	184.5 ^a
III-20b ²¹⁹	182.7 ^d	III-54 ¹⁹⁸	165.2 ^b
III-21a ²¹⁷	183.2 ^d	III-55 ²³⁹	157.6 ^b
III-21b ²¹⁹	182.4 ^d	III-56 ⁹⁸	178.2 ^g
III-22a ²²⁰	186.0 ^d	III-60a ²⁴¹	181.8 ^a
III-22b ²²⁰	186.0 ^d	III-60b ²⁴¹	182.4 ^a
III-22c ²²⁰	186.1 ^d	III-60c ²⁴¹	181.7 ^a
III-22d ²²⁰	186.1 ^d	III-60d ²⁴¹	179.1 ^a
III-22e ²²⁰	186.4 ^d	III-61 ²⁴²	188.9, 188.7 ^{h,g}
III-22f ²²⁰	186.7 ^d	III-61 ²⁴²	168.7 ^{i,g}
III-22g ²²⁰	185.8 ^d	III-62 ²⁴⁴	178.0 ^g
III-22h ²²⁰	185.6 ^d	III-63 ²³⁶	178.4 ^f
III-23 ^{220a}	184.9 ^d	III-64 ¹⁸⁷	177 ^b
III-24 ^{220a}	186.1 ^d	III-68 ²⁵⁴	176.7 ^g
III-25 ²²³	185.5 ^d		

^a CDCl₃. ^b CD₂Cl₂. ^c D[THF]. ^d C₆D₆. ^e Acetone-*d*₆. ^f CD₃CN. ^g DMSO-*d*₆. ^h Normal. ⁱ Abnormal.

Soon after, Arnold's group communicated the Cu(I) *N*-alkoxide-functionalized NHC complex obtained via the Ag carbene transfer route.¹⁸⁷ In the same year, Fraser and Woodward provided the first utilization of NHCs in the Cu-catalyzed conjugate addition of ZnEt₂ to enones.¹⁸⁸ In this case, Cu(II)–NHCs were presumably formed through the addition of free NHC to a Cu(II) source.¹⁸⁹ However, the catalytic systems were often prepared *in situ* without isolation.

In 2003, Sadighi's and Buchwald's groups reported the isolation of a neutral [Cu(NHC)Cl]-type complex and its use in the conjugate reduction of α,β -unsaturated cyclic enone and ester.¹⁹⁰ Motivated by this work, the synthesis of Cu(I)–

Scheme 43

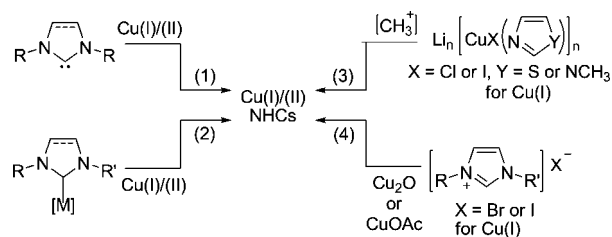

and Cu(II)–NHCs and their use in organic transformations arose rapidly. To date, most applications of Cu(I)– and Cu(II)–NHCs are focused on catalysis. Compared with their phosphine counterparts, Cu–NHCs with bulky substituents present many advantages as catalysts; they are more stable to air, water, and heat and, further, easy to prepare. There is also one report of preparation of polymeric Cu(I)–NHC in submicrometer spherical particles for potential heterogeneous catalysis.¹³⁸ Recently, two reviews on the catalytic applications of Cu(I)– and Cu(II)–NHC complexes have appeared.^{30,191}

4.2. General Synthetic Methods

Scheme 43 shows the four methods usually employed for the synthesis of Cu(I)– and Cu(II)–NHC complexes: (1) reaction of free carbenes with suitable copper sources; (2) transmetalation from relevant NHC complexes; (3) alkylation of azolylcuprates; (4) direct reaction of imidazolium salts with copper base.

In the first method, imidazolium salts are deprotonated by a strong base to produce free NHC ligands. The isolated NHCs are then reacted with copper sources to produce Cu(I)– and Cu(II)–NHC complexes. Cu(I)–NHC complexes are mostly prepared in a one-pot reaction of an azolium salt with a base and a copper source. In common practice, one uses NaOt-Bu, KOt-Bu, or KH as strong base, dry THF or acetonitrile as solvent, and Cu(I) halide as Cu source. When azolium salts with weak coordinating anions such as BF₄[−] or PF₆[−] are employed, [Cu(NHC)₂]⁺-type compounds are usually obtained instead of [Cu(NHC)(halide)] type complexes. Until now, the free carbene route has been the most used method for Cu(I)– and Cu(II)–NHC preparation.¹⁹¹

In the second method, Ag(I)–NHCs as carbene transfer agents, isolated or generated *in situ*, are often employed to prepare Cu(I)– and Cu(II)–NHCs.¹⁸⁹ One of the driving forces of the smooth transmetalation is the stronger Cu–NHC bond than the Ag–NHC bond, as predicted from theoretical calculations.¹⁸⁵ For many catalytic reactions, on site preparation of Cu(I)–NHC complexes is preferable.^{81,82b,136a,192–195} Attempts to prepare Cu(I)– and Cu(II)–NHCs using group 6 or 7 metal complexes as NHC transfer agents, however, have not been successful.^{196,197}

In the third method, alkylation of thiazolyl or imidazolylcuprates can produce Cu(I)–NHCs.¹⁸⁴ Details of this method will be mentioned in the appropriate place. In the fourth method, reaction of imidazolium halide with Cu₂O or CuOAc can give Cu(I)–NHCs. Till now, two examples of using Cu₂O^{98,186} and one of using CuOAc¹⁹⁸ are known. The ease of deprotonating the C²-proton by Cu₂O depends on the acidity of the imidazolium moiety.³⁹

A survey of the methods used to synthesize Cu(I)–NHCs indicates that over 60% of the papers describe the use of the free carbene method and only 22% the Ag–carbene

transfer route. A direct comparison between these two methods has been made in only two reports, one stated that the Ag–carbene transfer route gave a higher yield (section 4.3.4); the other mentioned a failure of the free carbene method (section 4.3.2). In the synthesis of Cu(II)–NHC complexes, the Ag–carbene transfer technique was utilized in two reports (sections 4.3.1 and 4.3.4) and the free carbene route (section 4.3.3) and the transfer from a lithium salt (section 4.3.1) in one each.

4.3. Formation of Cu(I)– and Cu(II)–NHCs

Similar to the Au(I)–NHCs, stable [Cu(NHC)(halide)]-type complexes represent a major theme in the chemistry of Cu(I)–NHCs; one of them is commercially available.¹⁹⁹ Many compounds containing the Cu(NHC) core can be prepared from [Cu(NHC)(halide)]. Those Cu(I)– and Cu(II)–NHC complexes that were synthesized and used without isolation will not be included in our discussion. Characterization of Cu(I)– and Cu(II)–NHCs relies mainly on ¹H and ¹³C NMR and single-crystal XRD analyses. The ¹³C_{NHC} δ values for the Cu(I)–NHC complexes are between 159.6 and 216.3 ppm (Table 3). For the unsaturated imidazol-2-ylidene complexes, δ values fall between 163.3 and 205 ppm, whereas for the saturated complexes, except one at 165 ppm, the range is 182.2 to 215 ppm. According to the Cambridge Crystallographic Data Centre, relatively few Cu(I)– and Cu(II)–NHC structures are known among coinage metal–NHCs. Well-characterized Cu(I)– and Cu(II)–NHC complexes usually contain sterically bulky N-substituents. In general, the structures of Cu(I)– and Cu(II)–NHCs are simpler than those of Ag(I)–NHCs and similar to those of Au(I)–NHCs.

Despite many review articles covering the catalytic properties of Cu(I)– and Cu(II)–NHCs, no comprehensive review has appeared on the synthesis of Cu(I)– and Cu(II)–NHCs. In this section, we arrange the discussion of Cu(I)– and Cu(II)–NHCs according to their bonding mode and nuclearity. Examples are given for the formation, bonding mode, and related reactions of the complexes.³⁹

4.3.1. Complexes Containing the Cu(NHC)₂ Core

Scheme 44 represents some simple complexes with a Cu(NHC)₂ core. Chronologically, the first [Cu(NHC)₂]⁺-type compound **III-1a** was synthesized via the free carbene route.³⁶ Thereafter, a series of [Cu(NHC)₂]⁺-type compounds **III-1b–p** were synthesized.^{200,201} Among them, compounds **III-1a–f**, **III-1h**, **III-1i**, **III-1n**, **III-1o**, and **III-1p** were structurally analyzed by single-crystal XRD. The steric congestion resulting from the linear arrangement of two NHC ligands on the Cu center could be minimized either by an increase in the torsion angle between the two NHCs (28°–86°) or by an increase in the Cu–NHC bond distance (1.9–2.0 Å). The compounds **III-1h**, **III-1i**, and **III-1j** with Dipp, *t*-Bu, and Ad substituents have large torsion angles (80°–85°). On the other hand, the steric congestion in **III-1n** is released mainly by increasing the Cu–NHC distance (2.000 Å).

Scheme 45 provides other types of NHCs with a similar coordination mode. Compound **III-2**, which has a six-membered NHC ring, was obtained by the free carbene route.²⁰² It shows a Cu–NHC bond of 1.934(2) Å with a large torsion angle (80.91°) between the NHC rings. The six-membered ring brings the Mes groups closer to the Cu(I)

Scheme 44

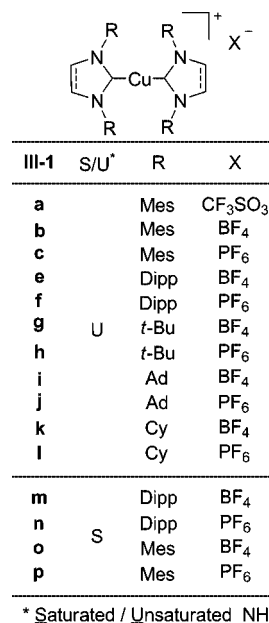

Scheme 45

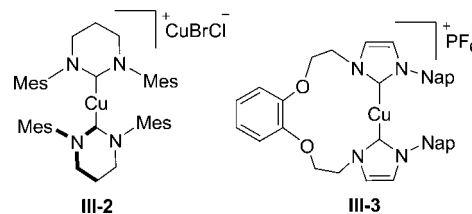

Scheme 46

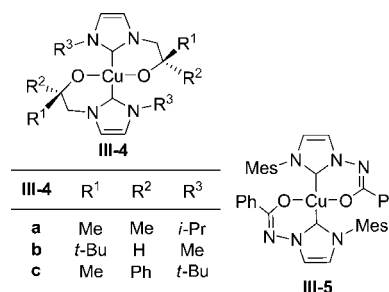

center than the five-membered rings. This results in a greater steric hindrance and hence a longer Cu–NHC bond along with a greater ring twist compared with the analogous five-membered ring compounds, **III-1o** and **III-1p**. Compound **III-3** with a chelating ligand was synthesized by the Ag–carbene transfer route.²⁰³ The Cu center was coordinated by two NHC rings twisted at ca. 53.4°.

Scheme 46 lists Cu(II)–NHC compounds **III-4**²⁰⁴ and **III-5**.²⁰⁵ Compounds **III-4** were obtained by reacting lithium *N*-alkoxide-carbenes with CuCl₂ or Cu(OTf)₂. The Ag–carbene transfer route was employed to synthesize C,O-chelating Cu(II)–NHC **III-5** by reacting a C,N-bonded Ag(I)–NHC with CuCl₂. The reaction is fast and gives a good yield.

4.3.2. [Cu(NHC)(Halide)]

Scheme 47 lists complexes of the type [Cu(NHC)(halide)] with symmetrical N-substituents on the NHC. Compounds **III-6–III-14** were synthesized through the free carbene route,^{202,206–214} whereas **III-15**⁶² and **III-16**¹⁹⁵ were synthesized via the Ag–carbene transfer route. Interestingly, the

Scheme 47

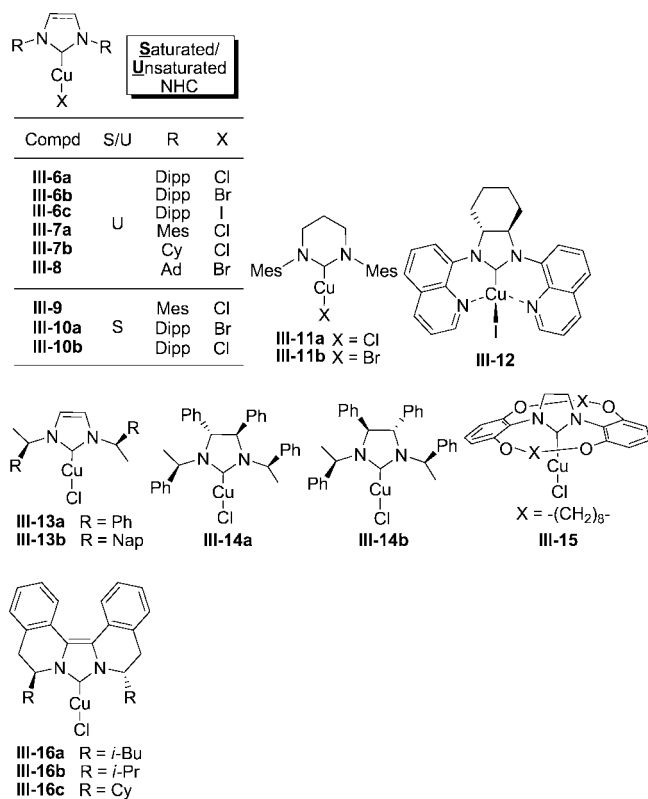

Scheme 48

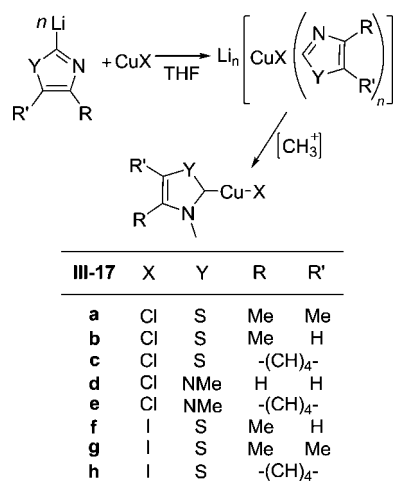

free carbene route failed to synthesize complex **III-15**. The two quinolyl groups at the NHC of complex **III-12** give inequivalent ¹H and ¹³C NMR patterns, suggesting the absence of a plane or axis of symmetry, presumably resulting from the coordination of the quinolyl nitrogen to Cu(I). Compounds **III-6**–**III-11** were used in catalysis and have been reviewed elsewhere.³⁰ Compounds **III-13**, **III-14**, and **III-16** were used to catalyze S_N2' allylic alkylation reactions. While **III-16** showed good ee values, **III-13** and **III-14** showed only moderate ee values. Compound **III-15**, bearing a bimaocyclic NHC, was used to catalyze the cyclopropanation of styrene and indene.¹⁹⁵

Scheme 48 presents neutral [Cu(NHC)(halide)]-type complexes **III-17**, where NHCs are mostly thiazol-2-ylidene. They were synthesized by methylating azolyocuprates with MeOTf. The azolyocuprates in turn were obtained from reaction of CuX (X = Cl or I) with lithiated thiazoles or

Scheme 49

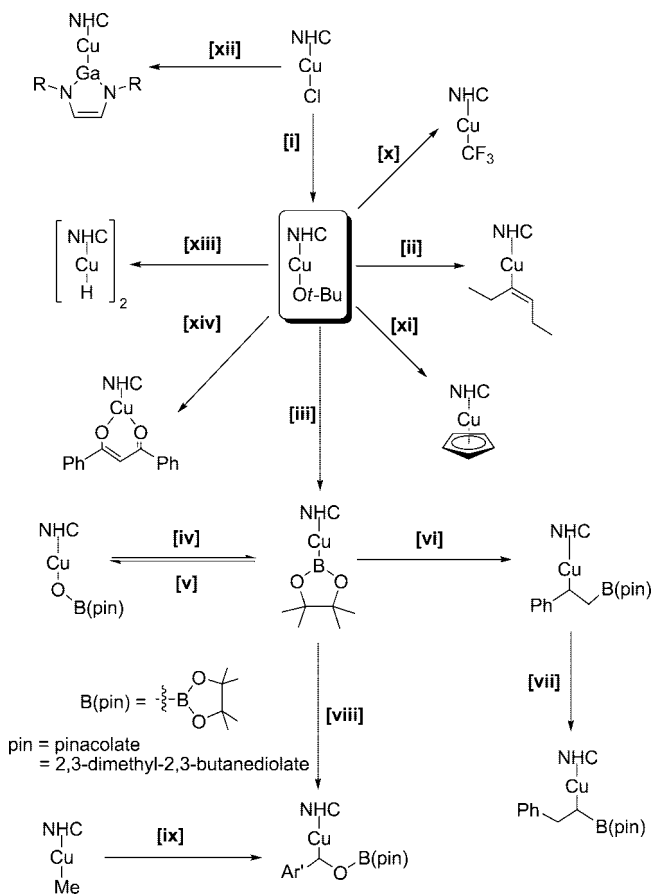

imidazoles.^{183,184} The ¹³C_{NHC} δ values for the thiazole complexes are in the range from 198.3 to 214.3 ppm, more downfield compared with those of imidazole-2-ylidene complexes. These chemical shifts are affected only slightly by the halide X but to a larger extent by the substituents R and R' at the backbone. Single-crystal XRD shows that complex **III-17a** crystallized in a Cl-bridged dimeric form, while **III-17b** was monomeric.

4.3.3. [Cu(NHC)(Ligand)]

Scheme 49 summarizes the preparation of [Cu(NHC)(ligand)]-type complexes, where the ligand is not a halide. Most of these compounds are prepared from [Cu(NHC)Cl]-type compounds in which only the Cu–ligand moieties are involved in the preparation; the NHC acts as a spectator. Scheme 49 also depicts the rich chemistry of [Cu(NHC)(Ot-Bu)]- and [Cu(NHC)(boryl)]-type compounds, pioneered by Sadighi's group. The reactions are numbered in lower case roman numerals in square brackets for cross-reference.

Equation 1 gives the formation of [Cu(NHC)(Ot-Bu)]-type compounds, **III-18a** and **III-18b**, obtained in good yield from the direct treatment of [Cu(NHC)Cl]-type compounds **III-6a** and **III-7b** with NaOt-Bu in THF, respectively (path i of Scheme 49).²¹⁵ In an attempt to synthesize compound **III-18a** in a one-pot reaction by mixing imidazolium chloride, CuCl, and NaOt-Bu (1:1:2 equiv.), a homoleptic [Cu(NHC)₂]⁺ species was obtained instead. The synthesis of Au(I)–NHC complexes by the free carbene route shows a similar trend. Subsequent reaction of complex **III-18a** with triethoxysilane in the presence of excess 3-hexyne gave [Cu(NHC)(vinyl)]-type complex **III-19** (path ii in Scheme

49; eq 2), the first hydrocupration product.²¹⁵ The vinylcopper species appeared to be more stable than expected.²¹⁶

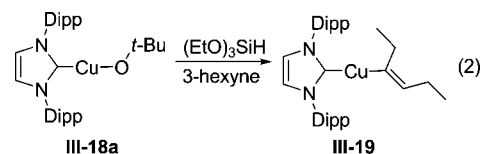
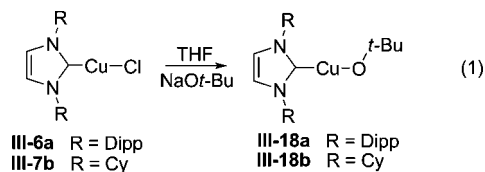

The first well-defined copper boryl complex **III-20a** was also obtained from compound **III-18a** through a reaction with $(\text{B}(\text{pin}))_2$ (path iii in Scheme 49).²¹⁷ Compound **III-20a** can catalytically reduce CO_2 to CO (eq 3). Reaction of this compound with CO_2 readily produced CO and compound **III-21a** (path v in Scheme 49), in which the boryl ligand was oxidized to a borate ligand through the insertion of an oxygen atom into a $\text{Cu}-\text{B}$ bond. Regeneration of **III-20a** by reacting **III-21a** with $(\text{B}(\text{pin}))_2$ completed the catalytic cycle (path iv in Scheme 49). The catalytic turnover frequency improved when the bulky *N*-Dipp substituent in complex **III-20a** was replaced by the sterically less demanding *N*-Cy substituent. DFT calculations have been performed to understand this mechanism.²¹⁸ The strong *trans* influence of the NHC ligand could weaken the $\text{Cu}-\text{B}$ bond and facilitate the O insertion reaction. A subsequent σ -bond metathesis between $(\text{B}(\text{pin}))_2$ and $[\text{Cu}(\text{NHC})(\text{OB}(\text{pin}))]$ would produce $\text{O}(\text{B}(\text{pin}))_2$ and $[\text{Cu}(\text{NHC})(\text{B}(\text{pin}))]$.

An interesting reaction occurs between $[\text{Cu}(\text{NHC})(\text{stannyl})]$ complex **III-20b** and CO_2 gas. Rather than a product from an insertion of CO_2 into the $\text{Cu}-\text{Sn}$ bond, a benzoate complex **III-21b** is produced by a net electrophilic cleavage of a $\text{Sn}-\text{Ph}$ bond.²¹⁹ The authors proposed two possible mechanisms for this reaction. The $\text{Sn}-\text{Ph}$ bond is cleaved by CO_2 in a concerted process with SnPh_2 extrusion. Alternatively, a two-step reaction takes place via an equilibrium between **III-20b** and a $[\text{Cu}(\text{NHC})\text{Ph}]$ complex, which reacts with CO_2 to form **III-21b**.

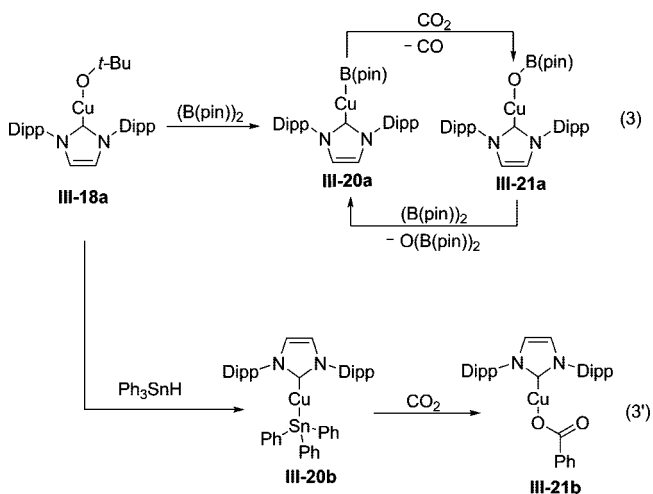

As shown in Scheme 50, **III-20a** is also active toward alkenes. Insertion of alkenes into the $\text{Cu}-\text{B}$ bond produces $[\text{Cu}(\text{NHC})(\beta\text{-borylalkyl})]$ -type complexes **III-22** with good yields and high regioselectivities (path vi in Scheme 49).^{220,221}

Scheme 50

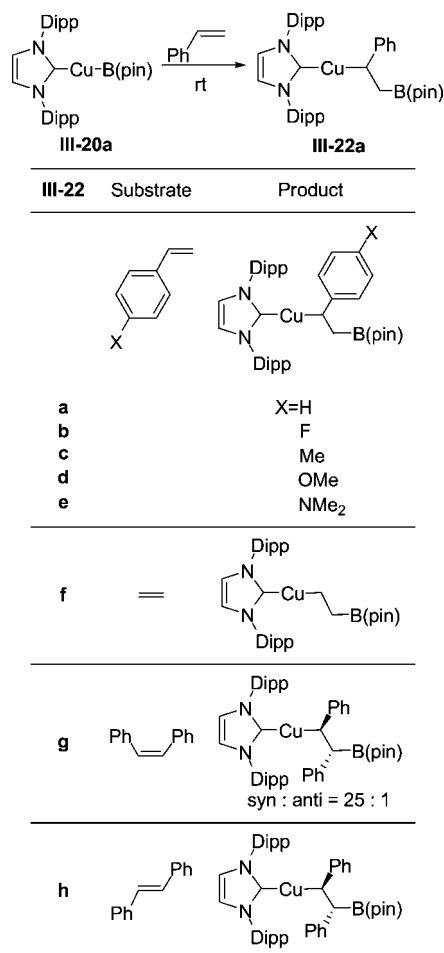

A Hammett plot of the rates of the insertion of 4-substituted styrenes into **III-20a** indicates that the substrate acts as an electrophile.

As shown in Scheme 51, complex **III-22a** isomerized to a new complex **III-23** upon heating at 70 °C for 24 h (path vii in Scheme 49; step a in Scheme 51).²²⁰ The authors proposed that a β -hydride elimination gave an intermediate $[\text{Cu}(\text{NHC})(\text{alkene})\text{H}]$ complex as shown; reinsertion of the resulting olefin generated the isomeric **III-23**. Three separate reactions (steps b–d in Scheme 51) were performed to support this mechanism. In the first experiment (reaction b), insertion of *trans*-2-(phenyl)vinyl(pinacol)boronate (denoted as **B-1**) to $[\text{Cu}(\text{NHC})\text{H}]$ (for structure see Scheme 57) was performed; compound **III-23** was obtained in 1 h at room temperature. The facile reaction of step b implies a high activation barrier of the β -hydride elimination step in reaction a. In another experiment monitored by ¹H NMR spectroscopy, reaction between **III-23** and *trans*-2-(*p*-tolyl)vinyl(pinacol)boronate (denoted as **B-2**) at 70 °C for 24 h led to the formation of **III-24** and **B-1** (reaction c). This indicates that the α -borylalkyl complex **III-23** also undergoes β -hydride elimination to form an identical intermediate. In a parallel experiment (reaction d), reacting **III-22a** with **B-2** produced a mixture of **III-23**, **III-24**, and **B-1**. These reactions further support the suggestion that an intermediate with a labile alkene is generated during the rearrangement. DFT calculation suggests that the insertion of an alkene molecule into a $\text{Cu}-\text{B}$ bond involves a nucleophilic attack of the boryl ligand on the coordinated alkene.^{220,222}

Scheme 51

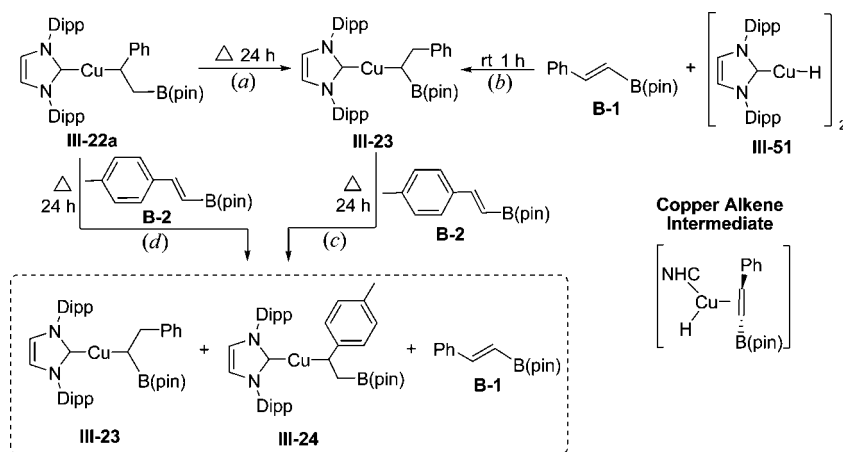

Scheme 52

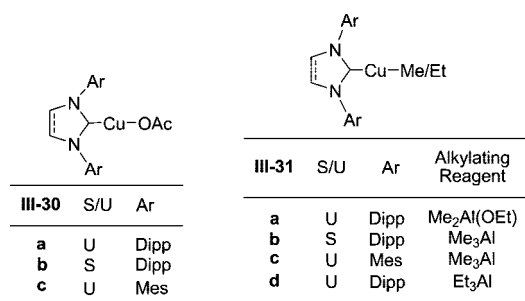

Complex **III-20a** is also reactive to aldehyde (path viii in Scheme 49). The insertion of a mesitaldehyde carbonyl carbon into a Cu–B bond gave **III-25** with a [Cu–C–O–B] linkage (eq 4).²²³ In an attempt to synthesize **III-26** with a [Cu–O–C–B] linkage, compound **III-31a** (for structure see Scheme 52) was reacted with α -borobenzyl alcohol (path ix in Scheme 49). Surprisingly, compound **III-25** was obtained instead (eq 5). Apparently an isomerization involving the breaking of a B–C bond and forming a B–O bond occurred. DFT calculations suggest that the [Cu–O–C–B] linkage is not stable, so the boryl group can migrate to the oxygen atom to give a complex with a [Cu–C–O–B] linkage.²²⁴

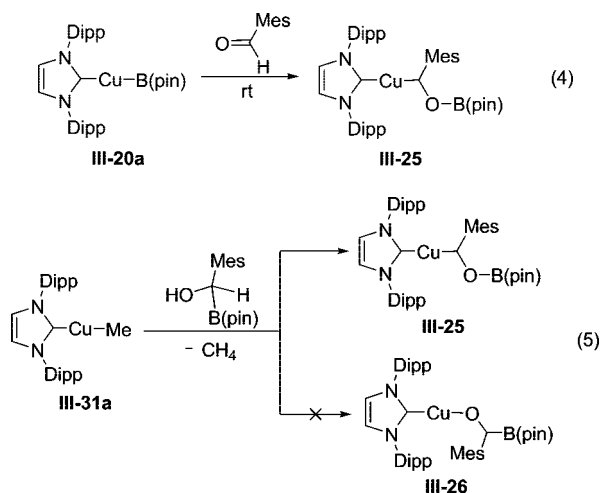

Reaction of [Cu(NHC)(*O*-*t*-Bu)]-type complex **III-18a** with CF₃SiMe₃ produced compounds **III-27** and **III-28** in a 1:4 ratio (path x in Scheme 49, eq 6).²²⁵ Silylation of the NHC ring backbone occurred in **III-28**. In a parallel reaction, treatment of a saturated NHC complex **III-52** (for structure

see Scheme 57) with CF₃SiMe₃ generated **III-29** as the sole Cu(I)–NHC complex (eq 7). These results indicate that silylation occurs only at unsaturated NHCs.

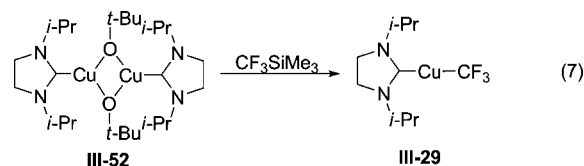
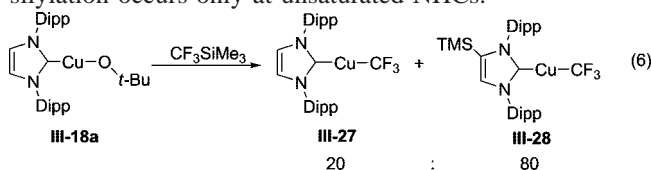

[Cu(NHC)(OAc)]-type compounds **III-30**, listed in Scheme 52, were prepared by the treatment of free carbene with Cu(I) acetate.^{226,227} Compounds **III-30** with a monodentate acetate ligand also exhibit rich chemistry. Treating **III-30** with suitable alkylating agents at low temperature produced two-coordinated [Cu(NHC)(alkyl)]-type compounds **III-31** (Scheme 52). The alkylating agent Me₂AlOEt was used for the preparation of **III-31a**, Me₃Al for **III-31b** and **III-31c**, and Et₃Al for **III-31d**.^{227,228} Further reaction of complex **III-31a** in benzene with CO₂ at 1 atm at room temperature produced the insertion product **III-30a** with a 98% isolated yield. This reaction was monitored by ¹H NMR in C₆D₆; a 95% completion was detected after 2.5 h.

Scheme 53 gives a series of Cu(I)–NHCs derived from the [Cu(NHC)(alkyl)]-type compounds **III-31**. Equation 8 represents the general reaction of **III-31** with RXH of PhNH₂, EtOH, PhOH, PhSH, PhCH₂SH, PhC≡CH, or pyrrole.^{228–230} Thus reacting **III-31** with aniline produced [Cu(NHC)(N–HPh)] complexes **III-32** along with methane/ethane gas. The formation of these gases was evidenced by ¹H NMR studies.²²⁸ Likewise, reaction of **III-31** with other substrates, for example, ethanol, phenol, benzenethiol, benzylmercaptan, phenylacetylene, and pyrrole,^{228–230} generated compounds [Cu(NHC)(OEt)] **III-33**, [Cu(NHC)(OPh)] **III-34**, [Cu(NHC)(SPh)] **III-35**, [Cu(NHC)(SCH₂Ph)] **III-36**, [Cu(NHC)(C≡CPh)] **III-37**, and [Cu(NHC)(pyrrolate)] **III-38**, respectively. The nucleophilicity of complexes **III-32a–c** toward bromoethane (eq 9) decreases (i) with the increasing steric bulk of the N-substituent and (ii) in the case of saturated NHC in the order **III-32c** > **III-32a** > **III-32b**.²³¹

[Cu(NHC)(OTf)]-type compound **III-39** along with ethane or butane was obtained by reacting either **III-31a** (R = Me)

Scheme 53

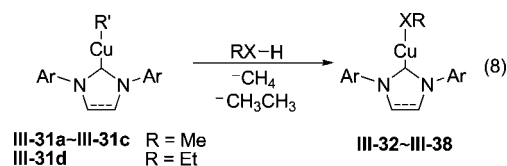

III-31a–III-31c R = Me
III-31d R = Et

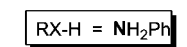

III-32	S/U	Ar
a	U	Dipp
b	S	Dipp
c	U	Mes

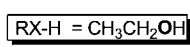

III-33	S/U	Ar
a	U	Dipp
b	S	Dipp
c	U	Mes

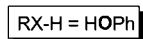

III-34	S/U	Ar
a	U	Dipp
b	S	Dipp
c	U	Mes

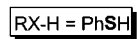

III-35	S/U	Ar
a	U	Dipp
b	S	Dipp

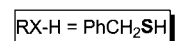

III-36	S/U	Ar
a	U	Dipp
b	S	Dipp

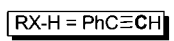

III-37	S/U	Ar
a	U	Dipp
b	S	Dipp

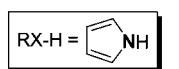

	S/U	Ar
III-38	U	Dipp

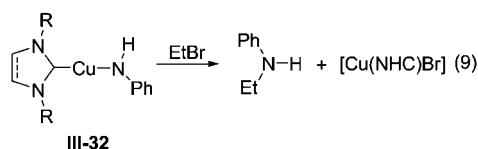

or **III-31d** (R = Et) with AgOTf (eq 10).²²⁷ Reacting a mixture of **III-31a** and **III-31d** with AgOTf also generated **III-39** along with ethane, propane, and butane (eq 11). This observation led to the proposition that reaction of Cu–alkyl complexes with a single electron oxidant AgOTf initially oxidizes Cu(I) to Cu(II) and is then followed by a reductive elimination of the alkyl group to produce Cu(I) complex **III-39** and R₂.

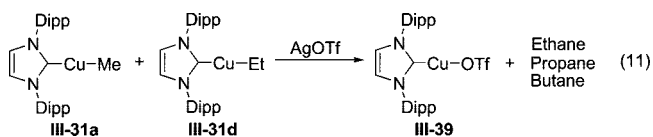
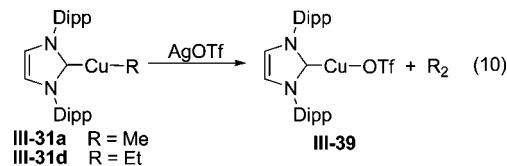

Scheme 54 shows neutral [Cu(NHC)(L)]-type compounds, where L is cyclopentadienyl, Ga(I) heterocycle, mesityl, or acetylide ligands. Compounds **III-40** (path xi in Scheme 49)²³² and **III-41** (path xii in Scheme 49)⁶⁴ were obtained by the reaction of a [Cu(NHC)Cl]-type compound with

Scheme 54

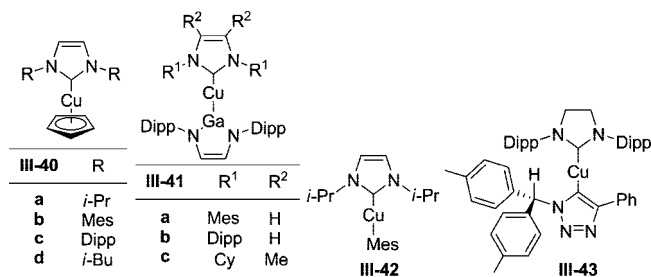

Scheme 55

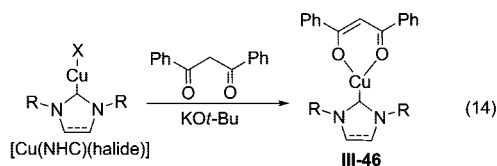
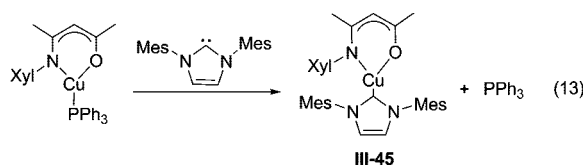
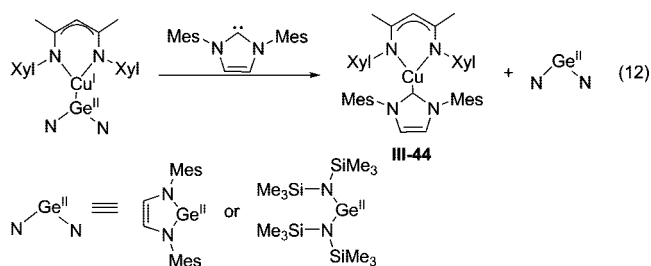

III-46	U/S	R
a		Dipp
b		Ad
c	U	Mes
d		Cy
e		Bh
f	S	Mes
g		Bn

cyclopentadienyl lithium and a Ga(I) heterocyclic salt, respectively. The structures of **III-40** showed an η⁵-type bonding mode for the cyclopentadienyl ligand. The longer Cu–Ga bonds (ca. 2.294 Å) than Cu–C bonds (ca. 1.918 Å) and the torsion angles of 24°–33° adopted by the compounds **III-41a** and **III-41b** might release the steric congestions from the four bulky N-substituents. A comparison of the structural results of [Cu(NHC)Cl]-, [Cu(NHC)(gallyl)]-, and [Cu(NHC)(boryl)]-type compounds suggests that the *trans* influence of the ligands other than NHCs goes in the order Cl < gallyl < boryl. Direct addition of a free NHC on Cu₅(Mes)₅ resulted in compound **III-42**.²³³ Reaction of [Cu(NHC)(C≡CPh)]-type compound **III-37b** with azido-4-tolylmethane gave **III-43**,²³⁰ a result suggesting a mechanism involving Cu-catalyzed [3 + 2] cycloaddition of azides with terminal alkynes.

Equations showing the preparation of some three-coordinated Cu(I)–NHCs are given in Scheme 55. Displacement of a germylene ligand on a β-diketiminato Cu(I) complex by an NHC produced **III-44** (eq 12).²³⁴ A similar displacement reaction shown in eq 13 produced **III-45**.²³⁵ The steric congestions in **III-44** and **III-45** were released

Scheme 56

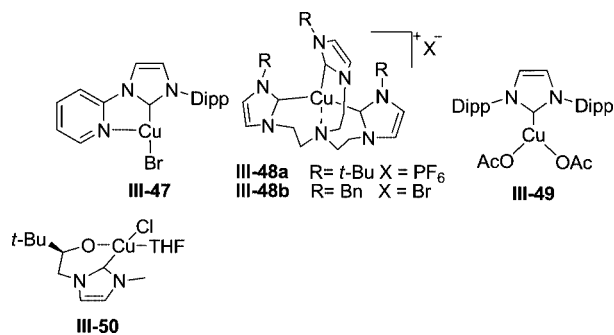

Scheme 57

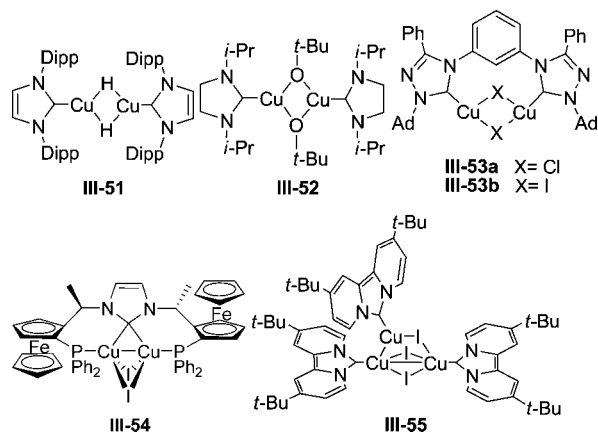

by the adoption of large torsion angles (75.22° and 82.19°, respectively). A series of Cu(I)–NHCs **III-46a–g** were prepared by replacing the halide in the [Cu(NHC)(halide)]-type complexes with dibenzoylmethanoate, a β -diketonate (path xiv in Scheme 49, eq 14).²¹⁰ These complexes acted as efficient Cu(I) catalysts for a three-component reaction of alkenes, aldehydes, and dimethylethoxysilanes.

Several miscellaneous Cu(I)– and Cu(II)–NHCs are presented in Scheme 56. Compound **III-47** was prepared by the treatment of a pyridyl-functionalized imidazolium salt with Cu₂O.¹⁸⁶ The compound crystallized in a T-shaped geometry with a Cu–N distance of 2.454(5) Å. N-Anchored tripodal Cu(I)–NHC complexes **III-48**²³⁶ and the Cu(II) complex **III-49**²³⁷ were produced through the free carbene

Scheme 58

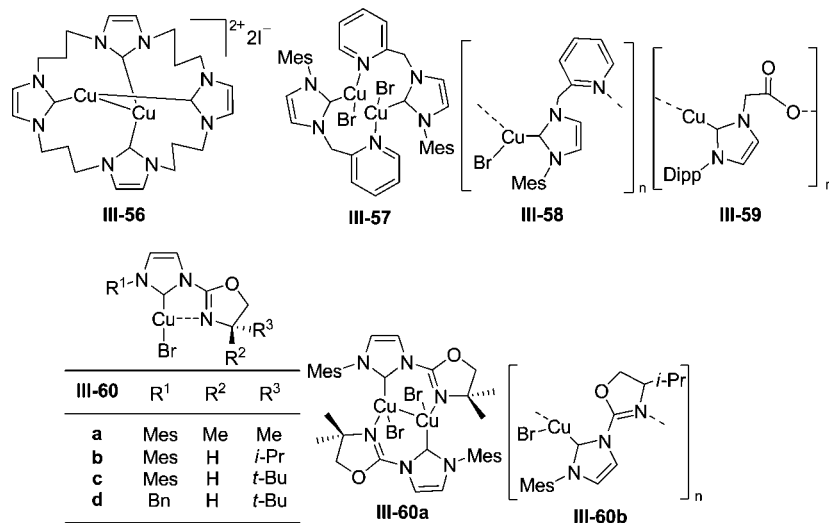

Scheme 59

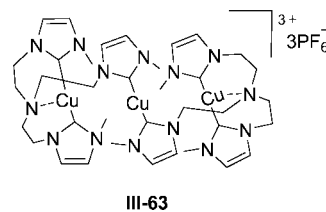
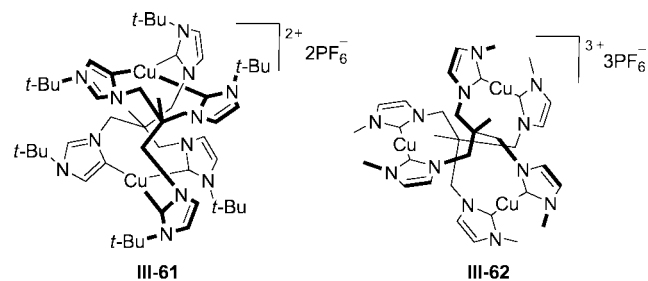

Scheme 60

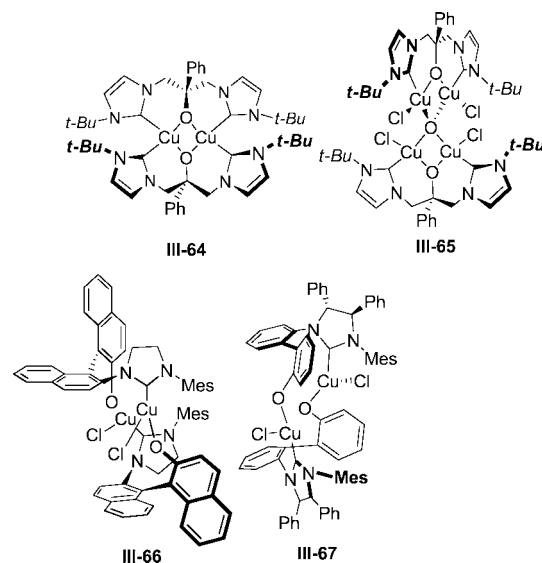

route. Complexes **III-48** might mimic enzyme systems and help in the study of biological processes. Structural analyses of **III-48a** and **III-48b** indicate that the Cu(I) center is coordinated with three NHCs in a pseudo-C₃-propeller

Scheme 61

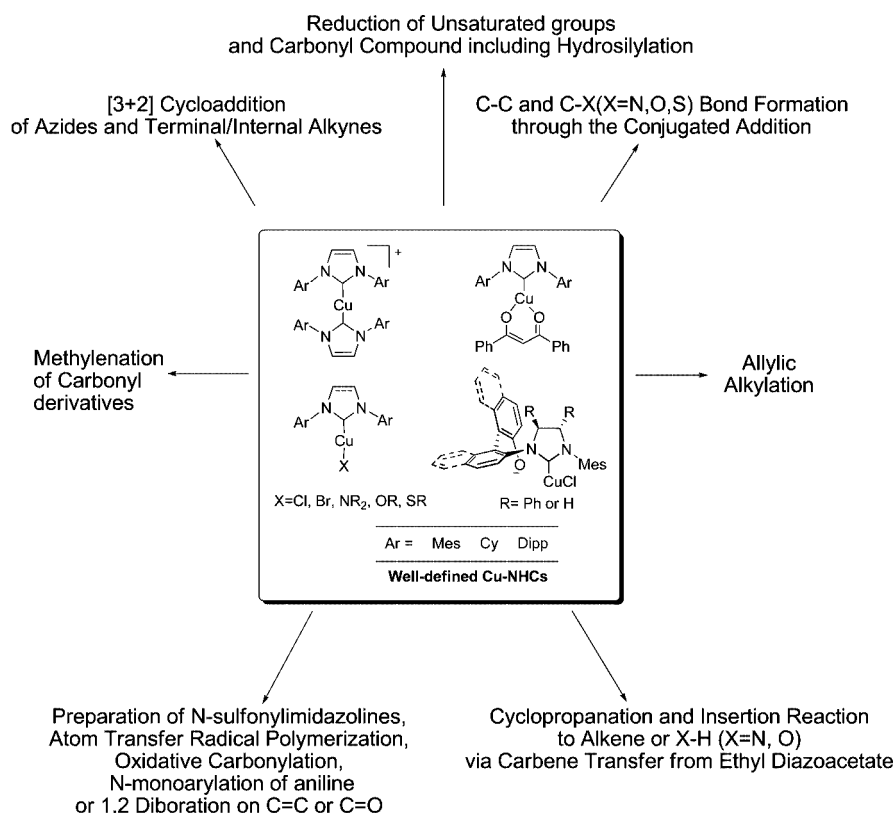

arrangement and a weakly interacting N atom. Oxidation of **III-48b** by AgOTf or, alternatively, direct reaction of Cu(OTf)₂ with the tripodal NHCs produced Cu(II)–NHCs. Based on EPR and SQUID magnetization measurements, a structure with a trigonal-planar ligand environment and a weak axial Cu···N interaction has been suggested for this Cu(II) compound. Compound **III-49** with two monodentate acetates has proved to be a robust and efficient precatalyst for hydrosilylation of carbonyl compounds. Compound **III-50** was produced by reaction of CuCl₂ with lithium *N*-alkoxide-carbenes; a tetra-coordinated environment on the Cu(II) ion was speculated.²⁰⁴ This complex could promote conjugate addition of an ethyl group to cyclohexenone.

4.3.4. Multinuclear Cu(I)– and Cu(II)–NHCs

Scheme 57 displays several dinuclear and a trinuclear Cu(I)–NHCs with bridging H, *O**t*-Bu, Cl, or I. The hydride-bridged complex **III-51** was prepared by the reaction of [Cu(NHC)(*O**t*-Bu)] **III-18a** with triethoxysilane (path xiii of Scheme 49).²¹⁵ NHC ligands are able to stabilize the Cu(I)–hydride species in lower nuclearity compared with the phosphine ligands. This hydride species is a powerful catalyst for the hydrosilylation of ketones and for the conjugate reduction of α,β -unsaturated cyclic enone and ester. In practical use, the hydride is usually prepared *in situ* by directly treating [Cu(NHC)(halide)]-type compounds with Na*O**t*-Bu/K*O**t*-Bu in the presence of silane.²¹⁶ The complex **III-52**, with two bridging *O**t*-Bu groups, was prepared by a procedure analogous to that for the monomeric compound **III-18**.²²⁵ The less sterically demanding *N*-substituents in **III-52** favor the bridging bonding mode, whereas the more sterically demanding *N*-substituents in **III-18a** lead to a mononuclear compound.

Dinuclear complexes **III-53a** and **III-53b**, with two triazole-based NHCs, have been synthesized via the free

carbene route.²³⁸ The structure of **III-53b** highlighted a Cu₂I₂ core bridged by a biscarbene ligand. The phosphine-derivatized ferrocenyl **III-54**, prepared by the free carbene route, is the first Cu(I)–NHC with a bridging-type carbene.¹⁹⁸ The two four-coordinated Cu(I)'s had a short Cu···Cu contact of ca. 2.356 Å. The free carbene route was also employed to prepare **III-55**.²³⁹ Its structure, consisting of a Cu₃I₃ core coordinated by three NHCs, could be viewed as an adduct of [Cu(NHC)I] and a dinuclear [Cu(NHC)I]₂ molecule, resulting in the formation of two Cu···Cu contacts (ca. 2.635 and 2.658 Å).

Scheme 58 lists Cu(I)–NHCs of nuclearity two or more with bridging ligands other than NHCs. Compound **III-56**, a homoleptic crown complex, was prepared by the Cu₂O route.⁹⁸ This compound exhibits two Cu(NHC)₂ moieties associated with a Cu···Cu contact of 2.553(2) Å. Unlike the analogous Ag(I) complex **I-64**, no intermolecular Cu···Cu interaction is observed. Two stoichiometrically identical [Cu(NHC)Br] compounds, **III-57** and **III-58**, were synthesized by reacting *N*-picolyl-functionalized imidazolium salts and Cu₂O in the presence of 4 Å molecular sieves in chlorinated solvents.¹⁸⁶ The dimeric form of **III-57** was obtained by recrystallization from CH₂Cl₂/ether, whereas polymeric **III-58** was isolated from CDCl₃. Compound **III-57** shows an intramolecular Cu···Cu distance of 2.647(2) Å. Each Cu(I) center in **III-57** and **III-58** is coordinated with NHC, Py, and Br ligands. Another polymeric Cu(I)–NHC, **III-59**, was obtained directly through the reaction of a zwitterionic imidazolium carboxylate with Cu₅(Mes)₅, which acted as a base and a source of Cu(I).²⁴⁰ The building block of the polymer consisted of a two-coordinated NHC–Cu–OC(O) moiety. A series of Cu(I)–NHC complexes **III-60** containing NHC ligands with oxazolonyl side arms were generated via the free carbene route.²⁴¹ They were all monomeric in solution, yet compound **III-60a** was crystallized as a dimer,

Scheme 62

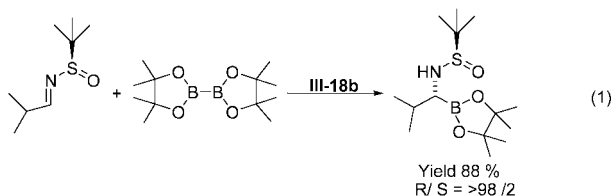
Synthesis of functionalized α -amino boronate esters

Aziridination of aliphatic alkene

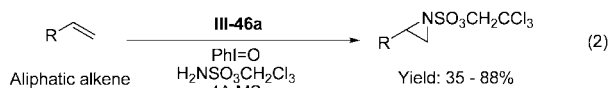

Trifluoromethylation

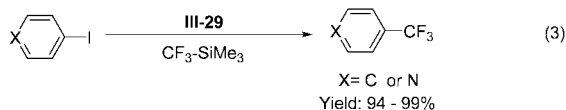

Carboxylation of aryl and alkenylboronic esters

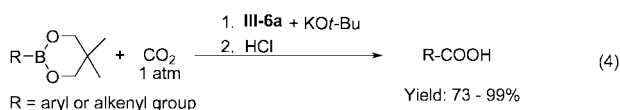

[3+2] cycloaddition reaction

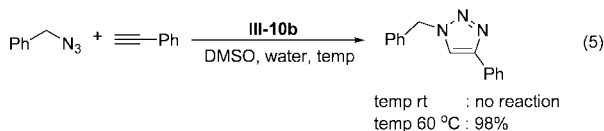

Stereocontrolled Conjugate Ethylation

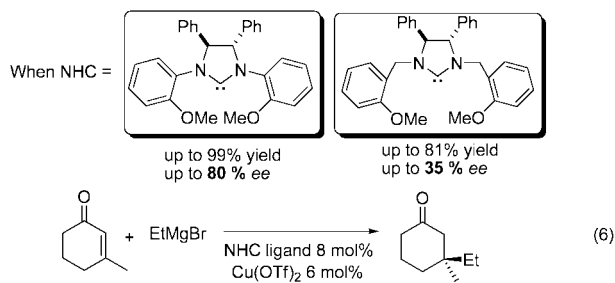

Ullmann-type Arylation Reaction

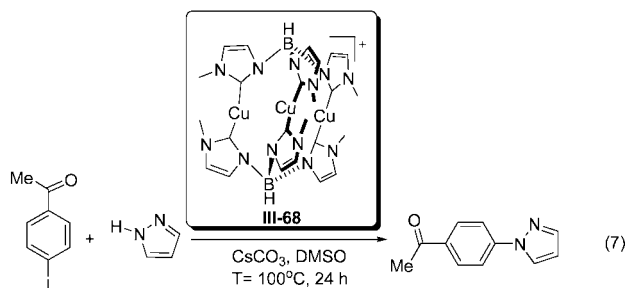

and **III-60b** was polymeric. This suggests that the R^2 and R^3 substituents at the oxazolinyl moiety influence the structure. The dimeric compound **III-60a** has a $\text{Cu}\cdots\text{Cu}$ distance of 2.707(2) Å.

Scheme 63

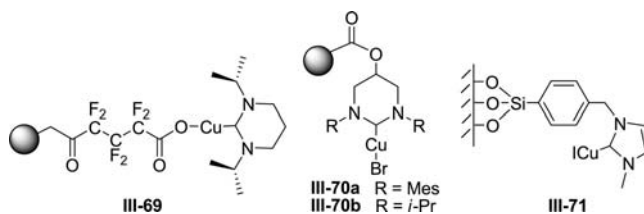

Scheme 64

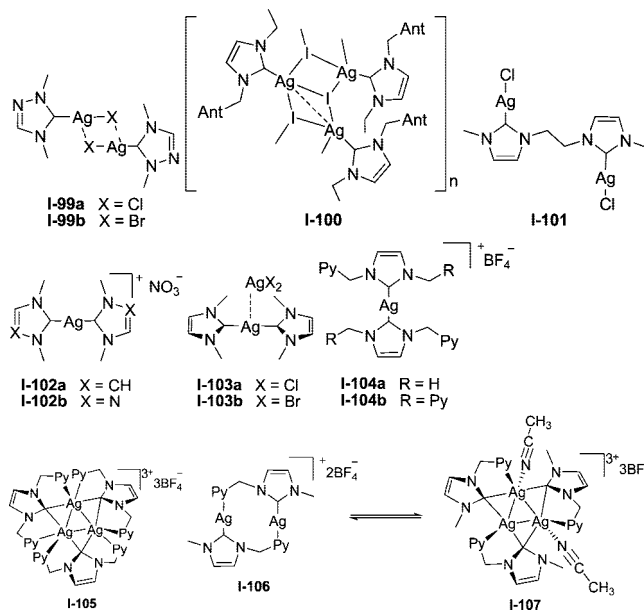

Scheme 59 lists two tripodal NHC complexes of Cu(I) with nuclearity of two and three. Compound **III-61** was obtained via the free carbene route and was structurally characterized.²⁴² It consists of two $[\text{Cu}(\text{NHC})_3]$ moieties, each with two normal and one abnormal NHC. Despite the known chemistry of abnormal metal–NHCs,²⁴³ **III-61** is the only known Cu(I)–NHC in which the NHCs adopt both an abnormal bonding mode and a normal binding mode. The authors suggested that the occurrence of the abnormal NHC might be attributed to the large steric hindrance of the *t*-Bu group at the NHC.²³⁶ Trinuclear compound **III-62** has been synthesized by both the Ag–carbene transfer route and the free carbene route; the former gave a better yield than the latter (56% vs 27%).²⁴⁴ This compound, having three linear NHC–Cu–NHC units, exhibits a D_3 symmetry in the solid state with the 3-fold axis passing through the central carbon atom anchoring three NHC ligands. Compound **III-63**, also containing three $[\text{Cu}(\text{NHC})_2]$ moieties, was synthesized through the Ag–carbene transfer route.²³⁶ The solid-state structure of **III-63** showed a central $[\text{Cu}(\text{NHC})_2]$ fragment flanked by two $[\text{Cu}(\text{NHC})_2]$ moieties bearing an additional weak $\text{Cu}\cdots\text{N}$ interaction.

Scheme 60 shows three Cu(I) or Cu(II) complexes, **III-64**–**III-67**, with *N*-alkoxide- and phenoxide-functionalized NHCs, prepared by the Ag–carbene transfer route.^{245,246} A special structural feature of compound **III-64** is a nearly square planar framework at the Cu(I) center, suggesting that an oxidation to Cu(II) might be possible.¹⁸⁷ Indeed, the authors later synthesized a Cu(II) complex **III-65** from **III-64**.²⁰⁴ The chiral Cu(II)–NHC compounds **III-66** and **III-67** are efficient catalysts for asymmetric allylic alkylation with good ee values.

Scheme 65

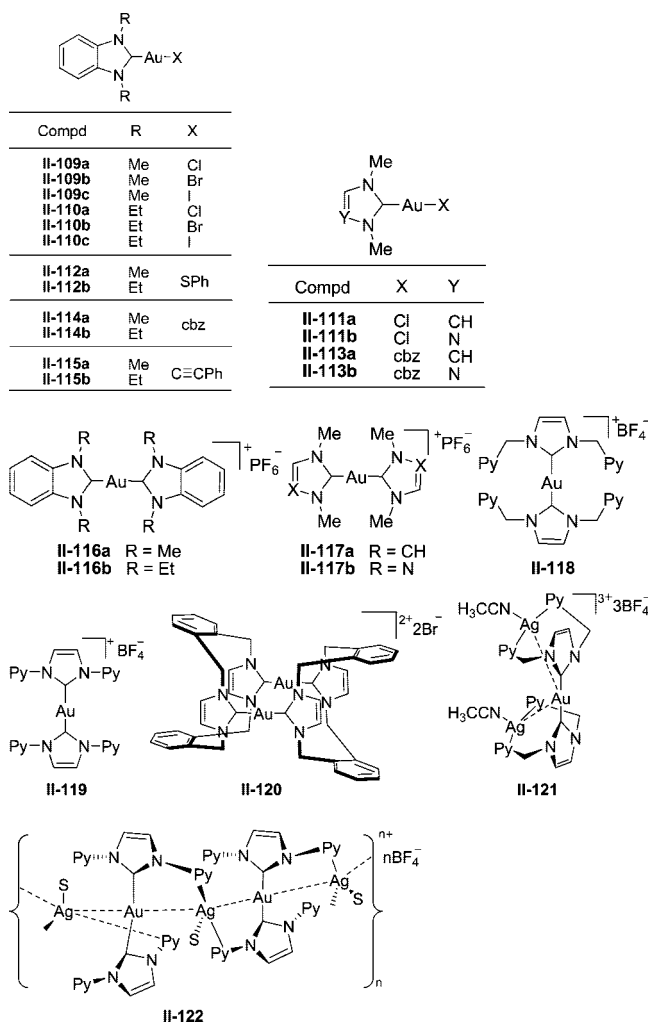

4.4. Catalysis

Considering the huge volume of literature on the catalytic applications of Cu(I)– and Cu(II)–NHCs, an overview of the development is necessary. Details of the use of Cu(I)– and Cu(II)–NHC complexes in catalysis have been addressed in several reviews.^{30,39,136b,191,247–249} To avoid duplication, we briefly summarize the major reviews.^{30,247,136b,191,248,249} This is then followed by a description of recent advancements that appeared after these reviews.

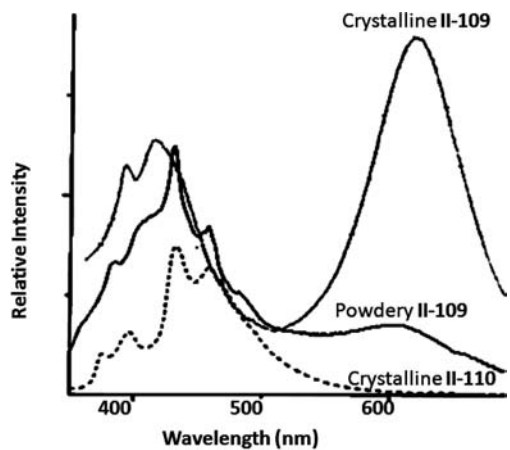

Figure 1. Solid state emission spectra of II-109 and II-110 at room temperature.

4.4.1. Past Events

Douthwaite, while reviewing metal-mediated asymmetric alkylation in general, summarized Cu(I)– and Cu(II)–NHC-catalyzed reactions of asymmetric allylic alkylation and analogous conjugate addition.^{136b} An important conclusion was drawn that the ee values of the products might be influenced by the chirality of the N or C^{4/5} substituents at the NHC ring. However, it is difficult to correlate the ee values with the structural configurations of the compounds, due to the insufficient structural data available. Later on, Falciola and Alexakis also partly covered Cu(I)– and Cu(II)–NHC-catalyzed asymmetric allylic alkylation reactions.²⁴⁸

Gunnoe, in reviewing the reactivity of Ru(II) and Cu(I) complexes, has discussed the chemistry of [Cu(NHC)(L)]-type compounds, where L is amido (III-32a), alkoxy (III-33a), aryloxy (III-34a), or thiolato (III-35a and III-36a) ligand.²⁴⁹ The author suggested that the high catalytic activity of these compounds could be attributed to the rich electron density on the anionic ligand, accelerating the “anti-Markovnikov” nucleophilic addition of N–H, O–H, and S–H across the olefin C=C bond. Kinetic study shows that Cu(I)–NHCs III-32, when L is NPh, are more active in these S_N2'-type reactions than the analogous phosphine complex [(dtbpe)Cu(NHPh)], where dtbpe = 1,2-bis(di-*t*-butylphosphanyl)ethane.²⁴⁹

Recently, Deutsch, Krause, and Lipshutz, in reviewing CuH-catalyzed reactions, discussed the general preparation of [Cu(NHC)H] species and their catalytic reactions, including conjugated reduction of α,β -unsaturated carbonyl compounds, hydrosilylation of carbonyl compounds, and S_N2'-reduction of alkynes.²¹⁶ The formation of vinyl cuprate III-19, along with its importance in organic synthesis, has also been introduced.

Lately, Díez-González and Nolan have surveyed the development and performance of [Cu(NHC)(ligand)]- and [Cu(NHC)₂]⁺-type complexes in homogeneous catalysis.^{30,191,247} These reviews gave a brief description of synthetic strategies for the known Cu(I)– and Cu(II)–NHC complexes. They also provided a comprehensive but condensed introduction to the catalytic properties of Cu(I)– and Cu(II)–NHC systems on organic transformations. Scheme 61 provides a short summary of the reactions covered.

4.4.2. Recent Advancements

Scheme 62 summarizes the ongoing research on the catalytic applications of Cu(I)– and Cu(II)–NHC complexes. Complex III-18b has been used as a catalyst to synthesize functionalized α -amino boronate esters from *N*-sulfinyl imine substrates with good yields and high diastereoselectivities (eq 1).²⁵⁰ An efficient aziridination of aliphatic alkene catalyzed by III-46a was also explored (eq 2).²⁵¹ In these reactions, the aziridines were produced with moderate to high yields. The well-defined [Cu(NHC)(CF₃)] complex III-29 has been effectively used in trifluoromethylation of organic halides under mild conditions for over 112 h (eq 3).²²⁵ Complex III-6a catalyzed the carboxylation of aryl and alkenylboronic esters with good yields (eq 4); reaction intermediates were isolated and characterized.²⁵²

Complex III-10b was found as a latent catalyst for the [3 + 2] cycloaddition reaction of azides with alkynes, in which the catalytic reaction was triggered only upon gentle heating in the presence of water (eq 5).²¹³ A recent study of

Table 4. Photoluminescent Properties of Ag–NHC Complexes^a

compd	λ_{\max} (λ_{ex}), nm		Ag...Ag distance, Å
	solid	solution	
I-10a ⁴⁸	459 ^b (264)	463 ^{b,c} (264) 454 ^{d,e} (244)	
I-10b ⁴⁸	445 ^b (264)	380 ^{b,c} (264) 445 ^{d,e} (244)	
I-11a ⁴⁸	443, <u>635</u> ^b (264)	442, 647 ^{b,c} (264) 453, 580 ^{d,e} (244)	3.403 ^h 3.550 ⁱ
I-11b ⁴⁸	440, <u>632</u> ^b (264)	435, 630 ^{b,c} (264) 447, 591 ^{d,e} (244)	3.771 ^h 3.505 ⁱ
I-12 ⁴⁹		483, 527, 580 ^{d,e} (244)	3.1970(12)
I-55 ¹¹⁰	442 (368)		3.223(1), 3.232(1)
I-59 ⁹¹		430 ^{b,f} (355)	2.8365(7) 2.8661(8)
I-71b ¹⁰¹		400, 420, 445 ^{b,f} (370)	3.77
I-76 ¹⁰⁵	365, 388, 410 (292)		3.252(1)
I-78a ¹⁰⁸	415, 436, 444, 470, 483, 496, <u>515</u> (230)		3.2695(7), 3.2404(7)
I-78b ¹⁰⁸	432, 445, 471, 487, 496, <u>523</u> (230)		3.1902(14), 3.1063(14)
I-79a ¹⁰⁹	425 (330)		3.208(2), 3.295(2)
I-79b ¹¹⁰	362, 463 (318)		3.113(1)
I-83 ¹¹²	442.8 (326)		2.911(1), 3.288(1)
I-85 ¹¹³	475.9 (304)		2.790(1), 2.791(1), 3.316(2), 2.792(2)
I-86 ¹¹³	486.7 (332)		2.784(1), 2.820(1), 3.293(2)
I-99a ⁵⁴	420 (300)		
I-99b ⁵⁴	420 (300)		
I-100 ²⁵⁹		400, 425, 450, 515 ^{b,g} (256)	
I-101 ⁵⁴	413 (295)		
I-102a ⁵⁴	395 (340)		
I-102b ⁵⁴	402 (302)		
I-103a ⁵⁴	392 (330), <u>544</u> (316)		
I-103b ⁵⁴	390 (340), <u>538</u> (324)		
I-104a ^{165b}	460 (370)		3.65
I-104b ^{165b}		413 ^{b,f} (305)	3.650
I-105 ²⁶¹		435 ^f (305)	2.7718(9), 2.7688(9), 2.7249(10)
I-106–I-107 ^{165b}	445 (370)	465 ^{b,f} 465, 401 ^{d,f} (370)	2.7765(8), 2.7832(8), 2.7598(8)

^a Wavelengths assigned to MC transitions are underlined. ^b RT. ^c CHCl₃. ^d 77 K. ^e EtOH/MeOH. ^f acetonitrile. ^g CH₂Cl₂. ^h Chair. ⁱ Boat.

stereocontrolled Cu-catalyzed conjugate ethylation revealed that the NHC N-substituent might be responsible for the generation of an asymmetric environment around the reaction site and controlling the ee values (eq 6).²⁵³ Equation 7 shows a trinuclear Cu(I) complex **III-68** used as a catalyst in the Ullmann-type arylation reaction.²⁵⁴ This complex, bearing tricarbene ligands, showed good reactivity, which has been attributed to its polynuclear nature.

Heterogeneous Cu(I)–NHC catalysts have been designed for easy separation and reuse by immobilization of homogeneous catalysts on a solid support (Scheme 63). Buchmeiser's group prepared Cu(I)–NHC complex **III-69** with a PS–DVB (polystyrene–divinylbenzene) support and applied it as a catalyst in the C=O cyanosilylation with an acceptable yield.²⁰² The products were almost free from any copper residues (<1 ppm) due to low copper loadings (12–71 μmol %) and immobilization. The same research group reported other examples of monolithic supported Cu(I)–NHC complexes **III-70a** and **III-70b** as catalysts in the cyanosilylation of carboxyl groups.²⁵⁵ In a continuous process, the catalysts remain active for days. Another attempt to design reusable catalyst has been made by the immobilization of Cu–NHC complex in silica. The silica-supported complex **III-71** was found to be highly reactive on the synthesis of propargylamines through a three-component coupling of aldehydes, amines, and alkynes at room temperature under solventless conditions.²⁵⁶ It can be reused ten times without significant loss of activity.

5. Photoluminescence

Photoluminescent properties of coinage metal–NHC complexes have been investigated less often compared with those of other coinage metal complexes.^{257,258} While the first report on Au–NHC complexes appeared in 1999,¹⁴⁷ Ag–NHC complexes were not studied until 2002.⁵⁴ Surprisingly, there is no report of luminescence from Cu–NHC complexes. The luminescence data for the Ag– and Au–NHCs, along with the metal...metal distances are summarized in Tables 4 and 5. Diagrams for the compounds not covered in the previous sections are provided in Schemes 64 and 65.

The emissive properties of Ag(I)– and Au(I)–NHC complexes usually involve transitions that are strongly affected by the nature of the ligand. Their assignments are based on a comparison with the spectra of the ligand precursors in terms of position and shape. Simple *N*-alkyl substituted [M(NHC)Cl] and [M(NHC)₂][anion] (M = Ag or Au) type complexes such as **I-101**,⁵⁴ **I-102**,⁵⁴ **I-110**,¹⁴⁷ and **II-117**¹⁶⁰ exhibit structured emission bands at λ_{\max} of 390–440 nm. Other *N*-functionalized NHCs can change the emissive behavior of the NHC complexes. For example, compound **I-104a**^{165b} with an *N*-methyl-*N'*-picolyl functionalization emits at λ_{\max} = 460 nm, whereas an *N,N'*-bipyridyl functionalization in **II-119**¹¹⁸ leads to a shift to 545 nm. The compounds with *N*-pyridyl groups appear to have emissions at longer wavelength compared with those with *N*-alkyl-substituted NHCs. The chromophoric *N*-CH₂Ant substituent in compound **I-100** strongly influences the emissive property,

Table 5. Photoluminescent Properties of Au–NHC Complexes^a

compd	λ_{\max} (λ_{ex}), nm		Au...Au distance, Å
	solid	solution	
II-14 ⁴⁹		427, 529, <u>575</u> ^{c,d} (244)	3.4042(2)
II-32 ^{159b}		400–500 ^{b,e} (355)	
II-68 ⁸⁴	472 (380)		
II-69 ^{165c}	541, ^b 506 ^c (348)		
II-70 ⁴⁸	411 (264)	438 ^{b,f} (264) 426 ^{c,f} (244)	
II-71 ⁴⁸	435 (264)	440 ^{b,f} (264) 449 ^{c,f} (244)	
II-78 ²⁷		396 ^{b,g} (313) <u>496</u> ^{b,g} (355)	
II-79 ^{165b}	416 ^b (300)	416 ^{b,c,h} (300)	3.0318(5) ⁱ
II-80 ^{165b}	423 ^b (300)	475 ^{b,h} ; 475, 423 ^{c,h} (300)	3.1730(5)
II-81 ⁸⁴	453 ^b (350)		2.9845(5)
II-82a ^{165c}	480, ^b 450 ^c (360)		2.9641(5) ⁱ
			2.9239(6) ⁱ
			2.8912(6)
			2.8633(6) ⁱ
			2.8873(6) ⁱ
II-82b ^{165c}	474, ^b 480 ^c (360)		2.835(1) ⁱ
			2.833(1) ⁱ
II-82c ^{165c}	522, ^b 453 ^c (360)		2.8448(5) ⁱ
			2.8940(5) ⁱ
II-82d ^{165c}	469, ^b 466 ^c (383)		2.8125(2) ⁱ
			2.8460(2) ⁱ
			2.8397(2) ⁱ
			2.9428(2) ⁱ
II-87 ⁴⁸	442, 630 (264)	429, <u>623</u> ^{b,f} (264); 449, 581 ^{c,f} (244)	
II-88 ⁴⁸	446, 631 (264)	428, <u>627</u> ^{b,f} (264); 446, 588 ^{c,f} (264)	
II-89 ¹⁰⁵	425 (358)		
II-90 ¹⁰⁹	431 (344)		3.292(1)
			3.276(1)
II-107 ¹⁵²	580 ^b (390)		
II-109a ¹⁴⁷	420, <u>620</u> (280)	334 ^{b,h} (350)	3.1664(10)
II-109b ¹⁴⁷	438, <u>620</u> (280)	334 ^{b,h} (350)	
II-109c ¹⁴⁷	440, <u>620</u> (280)	335 ^{b,h} (350)	
II-110a ¹⁴⁷	435 (280)	335 ^{b,h} (350)	
II-110b ¹⁴⁷	397 (280)	337 ^{b,h} (350)	
II-110c ¹⁴⁷	397 (280)	348 ^{b,h} (350)	
II-111a ¹⁶⁰	420, 650 (330)		3.5405(3)
II-111b ¹⁶⁰	410, 580 (335)		
II-112a ¹⁴⁷	425, 475 (280)	350 ^{b,h} (350)	
II-112b ¹⁴⁷	397 (280)	335 ^{b,h} (350)	
II-113a ¹⁴⁷	404, 584 (330)		3.9352(5)
II-113b ¹⁴⁷	410, 592 (330)		
II-114a ¹⁴⁷	413, 589 (330)		
II-114b ¹⁴⁷	438, 516 (330)		
II-115a ¹⁴⁷	421 (280)	421 ^{b,h} (350)	
II-115b ¹⁴⁷	421 (280)	340 ^{b,h} (350)	
II-116a ¹⁴⁷	441 (280)	325 ^{b,h} (350)	
II-116b ¹⁴⁷	397 (280)	335 ^{b,h} (350)	
II-117a ¹⁶⁰	422 (330)		
II-117b ¹⁶⁰	422 (307)		
II-118 ¹¹⁸		443 ^{b,h} (346)	
II-119 ¹¹⁸	545 (284)	345 ^{b,h} (284)	
II-120 ²⁶⁰		400, <u>780</u> ^{b,g} (260)	3.0485(3)
II-121 ¹¹⁸	446 (346)	443 ^h (346)	3.2197(17) ⁱ
			3.2819(17) ⁱ
			3.431(2) ^j
			3.3262(13)
II-122 ¹¹⁸	515 (284)	345 ^h (284)	2.8359(4)
			2.9042(4)

^a Wavelengths assigned to MC transitions are underlined. ^b RT. ^c 77 K. ^d EtOH/MeOH. ^e 2-MeTHF. ^f CHCl₃. ^g H₂O. ^h Acetonitrile. ⁱ Au...Au. ^j Ag...Ag.

as indicated by the well-resolved structure profile of Ant fluorescence from 380 to 550 nm in CH₂Cl₂.²⁵⁹

When molecular aggregation occurs as a result of M...M interactions, a featureless band involving a metal-centered (MC) transition may be present. The set of *N*-methyl- and *N*-ethyl-substituted [Au(NHC)X]-type compounds **II-109**–**II-111** nicely demonstrate this phenomenon. In the crystalline state, these compounds share a common NHC-based high-energy (HE) emission band at $\lambda_{\max} = 430 \pm 10$ nm.^{147,160} For the *N*-methyl-substituted compounds of **II-109** and **II-**

111, Au...Au interactions give rise to a featureless MC low-energy (LE) band between 580 and 650 nm. This band is not found for the *N*-ethyl-substituted compounds **II-110**, which lack Au...Au interactions.¹⁴⁷ Interestingly, when powder samples are used, the intensities of the LE bands for **II-109** and **II-111** decrease, presumably resulting from the diminishing number of Au...Au interactions. These facts support the MC nature of the LE band and are illustrated in Figure 1. Similar dual emissions are also found for

[Ag(NHC)₂][AgX₂] type compounds **I-103**, which possess extended Ag···Ag interactions.⁵⁴

[Au(NHC)(ligand)]-type compounds typically display dual emissions from NHCs or anionic ligands. The solid compounds **II-112–II-114** have a common structured HE band of NHC parentage at $\lambda_{\max} = 420 \pm 20$ nm; additional LE bands in the range between 475 and 590 nm are observed and are due to transitions involving an SPh (for compounds **II-112**) and a cbz ligand (for compounds **II-113** and **II-114**).¹⁴⁷ On the other hand, compound **II-32** shows only a structured emission from the pyrenyl ligand. This emission band is concentration-dependent in solution at 77 K due to the formation of excimers.^{159b}

The calix[4]arene like dinuclear complex **I-71b** emits in solution with ligand-based transitions at ca. 420 nm. It could serve as a C₆₀ fullerene indicator in solution, where the extent that the emission profile is suppressed upon the addition of fullerene is utilized to monitor the guest–host interactions.¹⁰¹ Dinuclear NHC compounds such as **II-78**,²⁷ **II-87**,⁴⁸ **II-88**,⁴⁸ and **II-120**²⁶⁰ with intramolecular Au···Au interactions also display dual emissions from NHC-based and MC-based transitions. Interestingly, **II-78** is stable for over 28 h in water toward glutathione. This property has been employed to investigate cellular processing using confocal fluorescence microscopy for potential medical applications.

Structureless emissions in the vicinity of 460 ± 20 nm are observed for the trinuclear compound **I-106**^{165b} and the tetranuclear compounds **I-79b**,¹¹⁰ **I-85**,¹¹³ and **I-86**¹¹³ in the solid state. The assignments of these luminescences are hindered by the complexity of their structures. The tetranuclear compound **II-90**¹⁰⁹ emits at $\lambda_{\max} = 431$ nm in the solid state, which is believed to be of intraligand rather than MC parentage, despite the relatively shorter Au···Au distances of ca. 3.3 Å. With relatively short Au···Ag distances, the heteronuclear compounds **II-79**,^{165b} **II-80**,^{165b} **II-81**,^{165b} **II-82**,^{165c} **II-89**,¹⁰⁵ **II-121**,¹¹⁸ and **II-122**¹¹⁸ are luminous within the range of 416–522 nm in the solid state. The nature of these emissions has not been studied.

For the Au(III) compound **II-107**, a charge transfer from the iodo ligands to the Au(III) metal center has been proposed to give an emission band at $\lambda_{\max} = 580$ nm.¹⁵² This is the only Au(III)–NHC complex reported so far to exhibit photoluminescence.

Although the emissive nature of many Ag–NHC and Au–NHC compounds is still not certain, it is presumed that the luminescence is mainly related to the ligands, though occasionally the metal···metal interaction provides additional MC emissions. There is no definite correlation between the MC emission band position and the strength of the metal···metal interactions. More experiments and theoretical calculations of triplet excited states are required for a better understanding of the nature of the luminescent properties. A proper modification of the NHC or a judicious choice of ligand would tune the emission properties for many potential applications, such as molecular LEDs, selective optical sensing of hazardous small molecules and heavy metals, optical telecommunication devices, biological sensors, and solar cell dyes.^{26,27,258}

6. Conclusions

The past decade has witnessed an enormous amount of research work on coinage metal–NHCs. This has been driven by the rapid development of various new chemistries, especially in catalysis. The ease of producing metal–NHCs

by the Ag₂O route has encouraged research in this field. Many complexes with C,Y-chelating NHCs, where Y is a hetero donor atom, have been successfully prepared. The retention of chirality during the entire process is a great asset to this technique. The strong σ -donor property of NHCs would also contribute to new findings of coinage metal–NHCs and catalytic performance. As mentioned in the preceding sections, many exciting results have already been found, yet many more can be expected to come. The easy accessibility of a wide variety of these metal complexes with properties that can be modified will certainly attract more investigation in this field.

Considerable effort has been devoted to find new therapeutic uses of silver and gold compounds. In this regard, the investigation of Ag(I)– and Au(I)–NHCs in medicinal applications has increased rapidly. The advantage of Ag(I)–NHCs over other silver compounds as antimicrobial agents for wound healing has been reported. This was attributed to their stability in water, which allowed for the slow release of Ag(I). Tuning the lipophilicity of Au(I)–NHCs to differentiate normal and tumor cells has been demonstrated. The easy modification these NHC complexes is an important factor to facilitate these studies. Despite some promising results, further studies are needed if there are to be major advances in drug discovery.

Due to their easy accessibility and modification, the fundamental science of coinage metal–NHCs has been extensively studied. Argentophilic and aurophilic interactions, which at times give rise to luminescent properties, have always been an interesting research subject. Structurally, metal–NHCs have a fan- or fence-like shape with ligands pointing toward the metal, thus forming a pocket. This is different from metal–phosphine complexes having a cone-like ligand pointing away from the metal. The influence of substituent change on the steric and the electronic properties of coinage metal–NHCs is not well understood, and further work is needed. Research is vibrant in the field, and one should expect many novel and exciting results in the near future.

7. Abbreviations

Acac	acetylacetonate
Ad	adamantyl
Ant	9-anthracenyl
Bh	benzhydryl
Bn	benzyl
Boc	<i>t</i> -butyloxycarbonyl
Bu	butyl
COD	1,5-cyclooctadiene
Cy	cyclohexyl
Dipp	2,6-dimethylphenyl
Et	ethyl
Fc	ferrocenyl
Hex	hexyl
Me	methyl
Ment	1-methyl-3-(+)-methylmenthoxide
Mes	2,4,6-trimethylphenyl
Nap	1-naphthylenyl
Np	neopentyl
NTf ₂	bis(trifluoromethylsulfonyl)amide
Ny	2,4-dimethyl-1,8-naphthridinyl
OAc	acetate
OTs	<i>p</i> -toluenesulfonamide
OTf	trifluoromethylsulfonate
Ph	phenyl
Pr	propyl

Py	2-pyridyl
Tht	tetrahydrothiophene
Tol	tolyl
Xyl	2,6-dimethyl

8. Acknowledgments

We especially thank Prof. K.-C. Peng for discussion of medicinal chemistry and Prof. F. Budenholzer at Fu Jen Catholic University for assisting in English editing. Moreover, we acknowledge the financial support from the National Science Council (Taiwan, ROC) (Grants NSC 96-2113-M-259-012 and NSC 97-2113-M-259-009-MY3) and National Dong-Hwa University.

9. References

- (1) (a) Glorius, F. *Top. Organomet. Chem.* **2007**, *21*, 1. (b) Bourissou, D.; Guerret, O.; Gabbai, F. P.; Bertrand, G. *Chem. Rev.* **2000**, *100*, 39.
- (2) Arduengo, A. J.; Harlow, R. L.; Kilne, M. *J. Am. Chem. Soc.* **1991**, *113*, 361.
- (3) (a) Enders, D.; Niemeier, O.; Henseler, A. *Chem. Rev.* **2007**, *107*, 5606. (b) Marion, N.; Díez-González, S.; Nolan, S. P. *Angew. Chem., Int. Ed.* **2007**, *46*, 2988.
- (4) Hahn, F. E.; Jahnke, M. C. *Angew. Chem., Int. Ed.* **2008**, *47*, 3122.
- (5) Liddle, S. T.; Edworthy, I. S.; Arnold, P. L. *Chem. Soc. Rev.* **2007**, *36*, 1732.
- (6) Crabtree, R. H. *J. Organomet. Chem.* **2005**, *689*, 5451.
- (7) Nolan, S. P., Ed. *N-Heterocyclic Carbenes in Synthesis*; Wiley-VCH: Weinheim, Germany, 2006.
- (8) Köhl, O. *Chem. Soc. Rev.* **2007**, *36*, 592.
- (9) Normand, A. T.; Cavell, K. J. *Eur. J. Inorg. Chem.* **2008**, 2781.
- (10) Corberán, R.; Ramírez, J.; Poyatos, M.; Perisa, E.; Fernández, E. *Tetrahedron: Asymmetry* **2006**, *17*, 1759.
- (11) Poater, A.; Ragone, F.; Giudice, S.; Costabile, C.; Dorta, R.; Nolan, S. P.; Cavallo, P. *Organometallics* **2008**, *27*, 2679.
- (12) Peris, E. *Top. Organomet. Chem.* **2007**, *21*, 83.
- (13) Wang, H. M. J.; Lin, I. J. B. *Organometallics* **1998**, *17*, 972.
- (14) (a) Garrison, J. C.; Youngs, W. J. *Chem. Rev.* **2005**, *105*, 3978. (b) Kascatan-Nebioglu, A.; Panzner, M. J.; Tessier, C. A.; Cannon, C. L.; Youngs, W. J. *Coord. Chem. Rev.* **2007**, *251*, 884. (c) Hindi, K. M.; Siciliano, T. J.; Durmus, S.; Panzner, M. J.; Medvetz, D. A.; Reddy, D. V.; Hogue, L. A.; Hovis, C. E.; Hilliard, J. K.; Mallet, R.; Tessier, C. A.; Cannon, C. L.; Youngs, W. J. *J. Med. Chem.* **2008**, *51*, 1577.
- (15) Lee, C. K.; Vasam, C. S.; Huang, T. W.; Wang, H. M. J.; Yang, R. Y.; Lee, C. S.; Lin, I. J. B. *Organometallics* **2006**, *25*, 3768.
- (16) Lin, I. J. B.; Vasam, C. S. *Coord. Chem. Rev.* **2007**, *251*, 642.
- (17) Hashmi, A. S. K. *Gold Bull.* **2004**, *37*, 51.
- (18) Marion, M.; Nolan, S. P. *Chem. Soc. Rev.* **2008**, 1776.
- (19) (a) Li, Z.; Brouwer, C.; He, C. *Chem. Rev.* **2008**, *108*, 3239. (b) Arcadi, A. *Chem. Rev.* **2008**, *108*, 3266. (c) Gorin, D. J.; Sherry, B. D.; Toste, F. D. *Chem. Rev.* **2008**, *108*, 3351. (d) Jiménez-Núñez, E.; Echavarren, A. M. *Chem. Rev.* **2008**, *108*, 3326. (e) Jiménez-Núñez, E.; Echavarren, A. M. *Chem. Commun.* **2007**, 333. (f) Shen, H. C. *Tetrahedron* **2008**, *64*, 7847. (g) Skouta, R.; Li, C. *Tetrahedron* **2008**, *64*, 4917. (h) Muzart, J. *Tetrahedron* **2008**, *64*, 5815. (i) Shen, H. *Tetrahedron* **2008**, *64*, 3885. (j) Michelet, V.; Toullec, P. Y.; Genêt, J. *Angew. Chem., Int. Ed.* **2008**, *47*, 4268.
- (20) Frémont, P.; Singh, R.; Stevens, E. D.; Petersen, J. L.; Nolan, S. P. *Organometallics* **2007**, *26*, 1376.
- (21) Barnard, P. J.; Berners-Price, S. J. *Coord. Chem. Rev.* **2007**, *251*, 1889.
- (22) Krishnamurthy, D.; Karver, M. R.; Fiorillo, E.; Orrú, V.; Stanford, S. M.; Bottini, N.; Barrios, M. *J. Med. Chem.* **2008**, *51*, 4790.
- (23) Ray, S.; Mohan, R.; Singh, J. K.; Samantaray, M. K.; Shaikh, M. M.; Panda, D.; Ghosh, P. *J. Am. Chem. Soc.* **2007**, *129*, 15042.
- (24) Schmidbaur, H. *Gold Bull.* **2000**, *33*, 3.
- (25) Lin, J. C. Y.; Tang, S. S.; Vasam, C. S.; You, W. C.; Ho, T. W.; Huang, C. H.; Sun, B. J.; Huang, C. Y.; Lee, C. S.; Hwang, W. S.; Chang, A. H. H.; Lin, I. J. B. *Inorg. Chem.* **2008**, *47*, 2543.
- (26) (a) Li, C. K.; Lu, X. X.; Wong, K. M. C.; Chan, C. L.; Zhu, N.; Yam, V. W. *Inorg. Chem.* **2004**, *43*, 7421. (b) Lagunas, M. C.; Fierro, C. M.; Pintauro-Alba, A.; Riva, H.; Betanzos-Lara, S. *Gold Bull.* **2006**, *40*, 135.
- (27) Barnard, P. J.; Wedlock, L. E.; Baker, M. V.; Berners-Price, S. J.; Joyce, D. A.; Skelton, B. W.; Steer, J. H. *Angew. Chem., Int. Ed.* **2006**, *45*, 5966.
- (28) Lin, I. J. B.; Vasam, C. S. *Can. J. Chem.* **2005**, *83*, 812.
- (29) Raubenheimer, H. G.; Cronje, S. *Chem. Soc. Rev.* **2008**, *37*, 1998.
- (30) Díez-González, S.; Nolan, S. P. *Aldrichimica Acta* **2008**, *41*, 43.
- (31) Jacobsen, H.; Correa, A.; Poater, A.; Costabile, C.; Cavallo, L. *Coord. Chem. Rev.* **2008**, published online, DOI: 10.1016/j.ccr.2008.06.006.
- (32) Boehme, C.; Frenking, G. *Organometallics* **1998**, *17*, 5801.
- (33) Nemcsok, D.; Wichmann, K.; Frenking, G. *Organometallics* **2004**, *23*, 3640.
- (34) Tonner, R.; Heydenrych, G.; Frenking, G. *Chem.—Asian J.* **2007**, *2*, 1555.
- (35) Hayes, J. M.; Viciano, M.; Peris, E.; Ujaque, G.; Lledos, A. *Organometallics* **2007**, *26*, 6170.
- (36) Arduengo, A. J.; Dias, H. V. R.; Calabrese, J. C.; Davidson, F. *Organometallics* **1993**, *12*, 3405.
- (37) Guerret, O.; Solé, S.; Gornitzka, H.; Trinquier, G.; Bertrand, G. *J. Am. Chem. Soc.* **1997**, *119*, 6668.
- (38) An unmindful mistake made by the then graduate student Wang allowed the development of this method to synthesize Ag(I)–NHCs by direct reacting of imidazolium salts with Ag₂O. In an experiment presumably to prepare Au(I)–NHCs, Wang, absent mindedly used Ag₂O as a base. When he rushed to report the formation of Au(I)–NHCs to Lin, he was asked to redo the experiment without gold compounds. In the product, Wang and Lin found a good quantity of Ag(I)–NHCs.
- (39) Arnold, P. L. *Heteroat. Chem.* **2002**, *13*, 534.
- (40) Lin, I. J. B.; Vasam, C. S. *Comments Inorg. Chem.* **2004**, *23*, 534.
- (41) (a) Sanderson, M. D.; Kamplain, J. W.; Bielawski, C. W. *J. Am. Chem. Soc.* **2006**, *128*, 16514. (b) Saravanakumar, S.; Oprea, A. I.; Kindermann, M. K.; Jones, P. G.; Heinicke, J. *Chem.—Eur. J.* **2006**, *12*, 3143. (c) Saravanakumar, S.; Oprea, A. I.; Kindermann, Heinicke, J.; Köckerling, M. *Chem. Commun.* **2006**, 640.
- (42) Khranov, D. M.; Lynch, V. M.; Bielawski, C. W. *Organometallics* **2007**, *26*, 6042.
- (43) Samantaray, M. K.; Katiyar, V.; Pang, K.; Nanavati, H.; Ghosh, P. *J. Organomet. Chem.* **2007**, *692*, 1672.
- (44) Ray, L.; Katiyar, V.; Raihan, M. J.; Nanavati, H.; Shaikh, M. M.; Ghosh, P. *Eur. J. Inorg. Chem.* **2006**, 3724.
- (45) Ray, L.; Katiyar, V.; Barman, S.; Raihan, M. J.; Nanavati, H.; Shaikh, M. M.; Ghosh, P. *J. Organomet. Chem.* **2007**, *692*, 4259.
- (46) Ray, L.; Shaikh, M. M.; Ghosh, P. *Organometallics* **2007**, *26*, 958.
- (47) Ray, L.; Barman, S.; Shaikh, M. M.; Ghosh, P. *Chem.—Eur. J.* **2008**, *14*, 6646.
- (48) Samantaray, M. K.; Pang, K.; Shaikh, M. M.; Ghosh, P. *Inorg. Chem.* **2008**, *47*, 4153.
- (49) Ray, L.; Shaikh, M. M.; Ghosh, P. *Inorg. Chem.* **2008**, *47*, 230.
- (50) Lee, K.-M.; Chen, J. C. C.; Huang, C.-J.; Lin, I. J. B. *CrystEngComm* **2007**, *9*, 278.
- (51) Melendez, R. E.; Hamilton, A. D. *Design of Organic Solid: Hydrogen-Bonded Tibbons, Tapes and Sheet as Motifs*; Springer-Verlag: Berlin, 1998, p 97.
- (52) Liao, C.-Y.; Chan, K.-T.; Chiu, P.-L.; Chen, C.-Y.; Lee, H.-M. *Inorg. Chim. Acta* **2008**, *361*, 2973.
- (53) Huang, W.; Zhang, R.; Zou, G.; Tang, J.; Sun, J. *J. Organomet. Chem.* **2007**, *692*, 3804.
- (54) Lee, K. M.; Wang, H. M. J.; Lin, I. J. B. *J. Chem. Soc., Dalton Trans.* **2002**, 2852.
- (55) Newman, C. P.; Clarkson, G. J.; Rourke, J. P. *J. Organomet. Chem.* **2007**, *692*, 4962.
- (56) Bittermann, A.; Härter, P.; Herdtweck, E.; Hoffmann, S. D.; Herrmann, W. A. *J. Organomet. Chem.* **2008**, *693*, 2079.
- (57) (a) Kascatan-Nebioglu, A.; Panzner, M. J.; Garrison, J. C.; Tessier, C. A.; Youngs, W. J. *Organometallics* **2004**, *23*, 1928. (b) Kascatan-Nebioglu, A.; Melaiye, A.; Hindi, K.; Durmus, S.; Panzner, M. J.; Hogue, L. A.; Mallet, R. J.; Hovis, C. E.; Coughenour, M.; Crosby, S. D.; Milsted, A.; Ely, D. L.; Tessier, C. A.; Cannon, C. L.; Youngs, W. J. *J. Med. Chem.* **2006**, *49*, 6811.
- (58) Oehlke, E.; Kückmann, T.; Abram, U. Z. *Anorg. Allg. Chem.* **2007**, *633*, 830.
- (59) Ogle, J. W.; Zhang, J.; Reibenspies, J. H.; Abboud, K. A.; Miller, S. A. *Org. Lett.* **2008**, *10*, 3677.
- (60) Türkmen, H.; Şahin, O.; Büyükgüngör, O.; Çetinkaya, B. *Eur. J. Inorg. Chem.* **2006**, 4915.
- (61) Winkelmann, O.; Näther, C.; Lüning, U. *J. Organomet. Chem.* **2008**, *693*, 2784.
- (62) Winkelmann, O.; Näther, C.; Lüning, U. *J. Organomet. Chem.* **2008**, *693*, 923.
- (63) Iglesias, M.; Beetstra, D. J.; Knight, J. C.; Ooi, L.-L.; Stasch, A.; Coles, S.; Male, L.; Hursthouse, M. B.; Cavell, K. J.; Dervisi, A.; Fallis, I. A. *Organometallics* **2008**, *27*, 3279.
- (64) Green, S. P.; Jones, C.; Mills, D. P.; Stasch, A. *Organometallics* **2007**, *26*, 3424.
- (65) Chiong, H. A.; Daugulis, O. *Organometallics* **2006**, *25*, 4054.
- (66) Cooke, C. E.; Rammial, T.; Jennings, M. C.; Pomeroy, R. K.; Clyburne, J. A. C. *Dalton Trans.* **2007**, 1755.

- (67) Liu, Q.-X.; Yin, L.-N.; Feng, J.-C. *J. Organomet. Chem.* **2007**, *692*, 3655.
- (68) Liu, Q.-X.; Yin, L.-N.; Wu, X.-M.; Feng, J.-C.; Guo, J.-H.; Song, H.-B. *Polyhedron* **2008**, *27*, 87.
- (69) Kühl, O.; Saravanakumar, S.; Ullah, F.; Kindermann, M. K.; Jones, P. G.; Köckerling, M.; Heinicke, J. *Polyhedron* **2008**, *27*, 2825.
- (70) Han, Y.; Hong, Y.-T.; Huynh, H. V. *J. Organomet. Chem.* **2008**, *693*, 3159.
- (71) Ullah, F.; Bajor, G.; Veszprémi, T.; Jones, P. G.; Heinicke, J. W. *Angew. Chem., Int. Ed.* **2007**, *46*, 2697.
- (72) Moore, L. R.; Cooks, S. M.; Anderson, M. S.; Schanz, H.-J.; Griffin, S. T.; Rogers, R. D.; Kirk, M. C.; Shaughnessy, K. *Organometallics* **2006**, *25*, 5151.
- (73) César, V.; Lugan, N.; Lavigne, G. *J. Am. Chem. Soc.* **2008**, *130*, 11286.
- (74) Belokon, Y. N.; Grachev, A. V.; Maleev, V. I.; Khrestalev, V. N.; Peregodov, A. S.; North, M. *Tetrahedron: Asymmetry* **2008**, *19*, 756.
- (75) Ros, A.; Monge, D.; Alcarazo, M.; Álvarez, E.; Lassaletta, J. M.; Fernández, R. *Organometallics* **2006**, *25*, 6039.
- (76) Roseblade, S.; Ros, A.; Monge, D.; Alcarazo, M.; Álvarez, E.; Lassaletta, J. M.; Fernández, R. *Organometallics* **2007**, *26*, 2570.
- (77) (a) Flahaut, A.; Baltaze, J.-P.; Roland, S.; Mangeney, P. *J. Organomet. Chem.* **2006**, *691*, 3498. (b) Flahaut, A.; Roland, S.; Mangeney, P. *Tetrahedron: Asymmetry* **2007**, *18*, 229. (c) Flahaut, A.; Roland, S.; Mangeney, P. *J. Organomet. Chem.* **2007**, *692*, 5754.
- (78) Visentin, F.; Togni, A. *Organometallics* **2007**, *26*, 3746.
- (79) Nishioka, T.; Shibata, T.; Kinoshita, I. *Organometallics* **2007**, *26*, 1126.
- (80) Tewes, F.; Schlecker, A.; Harms, K.; Glorius, F. *J. Organomet. Chem.* **2007**, *692*, 4593.
- (81) Brown, M. K.; May, T. L.; Baxter, C. A.; Hoveyda, A. H. *Angew. Chem., Int. Ed.* **2007**, *46*, 1097.
- (82) (a) Kacprzynski, M. A.; May, T. L.; Kazane, S. A.; Hoveyda, A. H. *Angew. Chem., Int. Ed.* **2007**, *46*, 4554. (b) Lee, Y.; Akiyama, K.; Gillingham, D. G.; Brown, M. K.; Hoveyda, A. H. *J. Am. Chem. Soc.* **2008**, *130*, 446.
- (83) Hahn, F. E.; Jahnke, M. C.; Pape, T. *Organometallics* **2006**, *25*, 5927.
- (84) Catalano, V. J.; Etogo, A. O. *Inorg. Chem.* **2007**, *46*, 5608.
- (85) (a) Wang, C.-Y.; Fu, C.-F.; Liu, Y.-H.; Peng, S.-M.; Liu, S.-T. *Inorg. Chem.* **2007**, *46*, 5779. (b) Wang, C.-Y.; Liu, Y.-H.; Peng, S.-M.; Liu, S.-T. *J. Organomet. Chem.* **2006**, *691*, 4012. (c) Wang, C.-Y.; Liu, Y.-H.; Peng, S.-M.; Chen, J.-T.; Liu, S.-T. *J. Organomet. Chem.* **2007**, *692*, 3976.
- (86) Li, F.; Bai, S.; Andy Hor, T. S. *Organometallics* **2008**, *27*, 672.
- (87) Samantary, M. K.; Pang, K.; Shaikh, M. M.; Ghosh, P. *Dalton Trans.* **2008**, 4893.
- (88) Busetto, L.; Cassani, M. C.; Femoni, C.; Macchioni, A.; Mazzoni, R.; Zuccaccia, D. *J. Organomet. Chem.* **2008**, *693*, 2579.
- (89) Ye, J.; Chen, W.; Wang, D. *Dalton Trans.* **2008**, 4015.
- (90) Chen, C.; Qiu, H.; Chen, W.; Wang, D. *J. Organomet. Chem.* **2008**, *693*, 3273.
- (91) Zhang, X.; Xi, Z.; Liu, A.; Chen, W. *Organometallics* **2008**, *27*, 4401.
- (92) Peng, H. M.; Song, G.; Li, Y.; Li, X. *Inorg. Chem.* **2008**, *47*, 8031.
- (93) Peng, H. M.; Webster, R. D.; Li, X. *Organometallics* **2008**, *27*, 4484.
- (94) Alcalde, E.; Ceder, R. M.; López, C.; Mesquida, N.; Muller, G.; Rodríguez, S. *Dalton Trans.* **2007**, 2696.
- (95) Dyson, G.; Frison, J.-C.; Simonovic, S.; Whitwood, A. C.; Douthwaite, R. E. *Organometallics* **2008**, *27*, 281.
- (96) Liu, Q.-X.; Zhao, X.-J.; Wu, X.-M.; Guo, J.-H.; Wang, X.-G. *J. Organomet. Chem.* **2007**, *692*, 5671.
- (97) Wang, J.-W.; Li, Q.-S.; Xu, F.-B.; Song, H.-B.; Zhang, Z.-Z. *Eur. J. Org. Chem.* **2006**, 1310.
- (98) McKie, R.; Murphy, J. A.; Park, S. R.; Spicer, M. D.; Zhou, S. *Angew. Chem., Int. Ed.* **2007**, *46*, 6525.
- (99) Willans, C. E.; Anderson, K. M.; Junk, P. C.; Barbour, L. J.; Steed, J. W. *Chem. Commun.* **2007**, 3634.
- (100) Liu, Q.-X.; Zhao, X.-J.; Wu, X.-M.; Yin, L.-N.; Guo, J.-H.; Wang, X.-G.; Feng, J.-C. *Inorg. Chim. Acta* **2008**, *361*, 2616.
- (101) Qin, D.; Zeng, X.; Li, Q.; Xu, F.; Song, H.; Zhang, Z.-Z. *Chem. Commun.* **2007**, 147.
- (102) Pugh, D.; Boyle, A.; Danopoulos, A. A. *Dalton Trans.* **2008**, 1087.
- (103) Dominique, F. J.-B.; Gornitzka, H.; Hermmert, C. *J. Organomet. Chem.* **2008**, *693*, 579.
- (104) Paulose, T. A. P.; Olson, J. A.; Quail, J. W.; Foley, S. R. *J. Organomet. Chem.* **2008**, *693*, 3405.
- (105) Liu, A.; Zhang, X.; Chen, W.; Qiu, H. *Inorg. Chem. Commun.* **2008**, *11*, 1128.
- (106) Papini, G.; Bandoli, G.; Dolmella, A.; Lobbia, G. G.; Pellei, M.; Santini, C. *Inorg. Chem. Commun.* **2008**, *11*, 1103.
- (107) Fränkel, R.; Kniczek, J.; Ponikwar, W.; Nöth, H.; Polborn, K.; Fehlhammer, W. P. *Inorg. Chim. Acta* **2001**, *312*, 23.
- (108) Ye, J.; Jin, S.; Chen, W.; Qiu, H. *Inorg. Chem. Commun.* **2008**, *11*, 404.
- (109) Zhou, Y.; Chen, W. *Organometallics* **2007**, *26*, 2742.
- (110) Zhou, Y.; Zhang, X.; Chen, W.; Qiu, H. *J. Organomet. Chem.* **2008**, *693*, 205.
- (111) Scheele, U. J.; Georgiou, M.; John, M.; Dechert, S.; Meyer, F. *Organometallics* **2008**, *27*, 5146.
- (112) Xi, Z.; Zhang, X.; Chen, W.; Fu, S.; Wang, D. *Organometallics* **2007**, *26*, 6636.
- (113) Liu, B.; Chen, W.; Jin, S. *Organometallics* **2007**, *26*, 3660.
- (114) (a) Zinner, S. C.; Herrmann, W. A.; Kühn, F. E. *J. Organomet. Chem.* **2008**, *693*, 1543. (b) Zinner, S. C.; Herrmann, W. A.; Kühn, F. E. *Tetrahedron: Asymmetry* **2008**, *19*, 1532.
- (115) Amyes, T. L.; Diver, S. T.; Richard, J. P.; Rivas, F. M.; Toth, K. *J. Am. Chem. Soc.* **2004**, *126*, 4366.
- (116) Dupont, J. J. *Braz. Chem. Soc.* **2004**, *15*, 341.
- (117) Chen, J. C. C.; Lin, I. J. B. *Organometallics* **2000**, *19*, 5113.
- (118) Catalano, V. J.; Malwitz, M. A.; Etogo, A. O. *Inorg. Chem.* **2004**, *43*, 5714.
- (119) Magill, A. M.; Cavell, K. J.; Yates, B. F. *J. Am. Chem. Soc.* **2004**, *126*, 8717.
- (120) Jacobsen, H.; Correa, A.; Costabile, C.; Cavallo, L. *J. Organomet. Chem.* **2006**, *691*, 4350.
- (121) Kim, Y.-J.; Streitwieser, A. *J. Am. Chem. Soc.* **2002**, *124*, 5757.
- (122) Bildstein, B.; Malaun, M.; Kopacka, H.; Wurst, K.; Mitterböck, M.; Ongania, K.; Opromolla, G.; Zanello, P. *Organometallics* **1999**, *18*, 4325.
- (123) (a) Fei, Z.; Zhao, D.; Geldbach, T. J.; Scopelliti, R.; Dyson, P. J. *Chem.—Eur. J.* **2004**, *10*, 4886. (b) Palimlar, S. S.; Siddiqui, S. A.; Daniel, T.; Lahoti, R. J.; Srinivasan, K. V. *J. Org. Chem.* **2003**, *68*, 9371.
- (124) Tulloch, A. A. D.; Danopoulos, A. A.; Winston, S.; Kleinhenz, S.; Eastham, G. J. *Chem. Soc., Dalton Trans.* **2000**, 4499.
- (125) Canal, J.; Rammial, T.; Langlois, L. D.; Abernethy, C. D.; Clyburne, J. A. C. *J. Chem. Educ.* **2008**, *85*, 416.
- (126) Guthrie, J. P.; More O'Ferrall, R. A.; O'Donoghue, A. C.; Waghorne, W. E.; Zrinski, I. *J. Phys. Org. Chem.* **2003**, *16*, 582.
- (127) Unpublished results from Lin's group.
- (128) Zhao, L.; Zhang, C.; Zhou, L.; Zhang, Y.; Ying, J. Y. *J. Am. Chem. Soc.* **2008**, *130*, 12586.
- (129) Frémont, P.; Scott, N. M.; Stevens, E. D.; Rammial, T.; Lightbody, O. C.; Macdonald, C. L. B.; Clyburne, J. A. C.; Abernethy, C. D.; Nolan, S. P. *Organometallics* **2005**, *24*, 6301.
- (130) Wang, X.; Liu, S.; Weng, L. H.; Jin, G. X. *Organometallics* **2006**, *25*, 3565.
- (131) Pytkowicz, J.; Roland, S.; Mangeney, P. *J. Organomet. Chem.* **2001**, *631*, 157.
- (132) Appelhans, L. N.; Incarvito, C. D.; Crabtree, R. H. *J. Organomet. Chem.* **2008**, *693*, 2761.
- (133) Ramírez, J.; Corberán, R.; Sanaú, M.; Peris, E.; Fernandez, E. *Chem. Commun.* **2005**, 3056.
- (134) Samantary, M. K.; Katiyar, V.; Roy, D.; Pang, K.; Nanavati, H.; Stephen, R.; Sunoj, R. B.; Ghosh, P. *Eur. J. Inorg. Chem.* **2006**, 2975.
- (135) (a) Sentman, A. C.; Csihony, S.; Nyce, G. W.; Waymouth, R. M.; Hedrick, J. L. *Polym. Prepr.* **2004**, *45*, 299. (b) Sentman, A. C.; Csihony, S.; Nyce, G. W.; Waymouth, R. M.; Hedrick, J. L. *J. Org. Chem.* **2005**, *70*, 2391.
- (136) (a) Winn, C. L.; Guillen, F.; Pytkowicz, J.; Roland, S.; Mangeney, P.; Alexakis, A. *J. Organomet. Chem.* **2005**, *690*, 5672. (b) Douthwaite, R. E. *Coord. Chem. Rev.* **2007**, *251*, 702.
- (137) (a) Melaiye, A.; Simons, R. S.; Milsted, A.; Pingitore, F.; Wesdemiotis, C.; Tessier, C. A.; Youngs, W. J. *J. Med. Chem.* **2004**, *47*, 973. (b) Melaiye, A.; Sun, Z.; Hindi, K.; Milsted, A.; Ely, D.; Reneker, D. H.; Tessier, C. A.; Youngs, W. J. *J. Am. Chem. Soc.* **2005**, *127*, 2285.
- (138) Park, K. H.; Ku, I.; Kim, H. J.; Son, S. U. *Chem. Mater.* **2008**, *20*, 1673.
- (139) (a) Chianese, A. R.; Li, X.; Janzen, M. C.; Faller, J. W.; Crabtree, R. H. *Organometallics* **2003**, *22*, 1663. (b) Chianese, A. R.; Kovacevic, A.; Zeglis, B. M.; Faller, J. W.; Crabtree, R. H. *Organometallics* **2004**, *23*, 2461. (c) Voutchkova, A. M.; Appelhans, L. N.; Chianese, A. R.; Crabtree, R. H. *J. Am. Chem. Soc.* **2005**, *127*, 17624.
- (140) Çetinkaya, B.; Dixneuf, P.; Lappert, M. F. *J. Chem. Soc., Dalton Trans.* **1974**, 1827.
- (141) Fehlhammer, W. P.; Bartel, K. *Angew. Chem., Int. Ed. Engl.* **1974**, *13*, 599.
- (142) Bonati, F.; Burini, A.; Pietroni, B. R.; Bovio, B. *J. Organomet. Chem.* **1989**, *375*, 147.
- (143) Raubenheimer, H. G.; Scott, F.; Roos, M.; Otte, R. *Chem. Commun.* **1990**, 1722.
- (144) Kuhlkamp, P.; Raubenheimer, H. G.; Field, J. S.; Desmet, M. J. *J. Organomet. Chem.* **1998**, *552*, 69.

- (145) Britten, J. F.; Lock, C. J. L.; Wang, Z. *Acta Crystallogr.* **1992**, *C48*, 1600.
- (146) Lee, K. M.; Lee, C. K.; Lin, I. J. B. *Angew. Chem., Int. Ed. Engl.* **1997**, *36*, 1850.
- (147) Wang, H. M. J.; Chen, C. Y. L.; Lin, I. J. B. *Organometallics* **1999**, *18*, 1216.
- (148) Schneider, S. K.; Herrmann, W. A.; Herdtweck, E. Z. *Anorg. Allg. Chem.* **2003**, *629*, 2363.
- (149) Barnard, P. J.; Baker, M. V.; Skelton, B. W.; White, A. H.; Berners-Price, S. J. *Inorg. Biochem.* **2004**, *98*, 1642.
- (150) Özdemir, I.; Denizci, A.; Öztürk, H. T.; Çetinkaya, B. *Appl. Organomet. Chem.* **2004**, *18*, 318.
- (151) (a) Ku, R. Z.; Huang, J. C.; Cho, J. Y.; Kiang, F. M.; Reddy, K. R.; Chen, Y. C.; Lee, K. J.; Lee, J.-H.; Lee, G. H.; Peng, S. M.; Liu, S. T. *Organometallics* **1999**, *18*, 2145. (b) Kessler, F.; Szesni, N.; Maass, C.; Hohberger, C.; Weibert, B.; Fischer, H. J. *Organomet. Chem.* **2007**, *692*, 3005.
- (152) Jothibasu, R.; Huynh, H. V.; Koh, L. L. *J. Organomet. Chem.* **2008**, *693*, 374.
- (153) Raubenheimer, H. G.; Olivier, P. J.; Lindeque, L.; Desmet, M.; Hrusak, J.; Kruger, G. J. *J. Organomet. Chem.* **1997**, *544*, 91.
- (154) (a) Baker, M. V.; Barnard, P. J.; Berners-Price, S. J.; Brayshaw, S. K.; Hickey, J. L.; Skelton, B. W.; White, A. H. *J. Organomet. Chem.* **2005**, *690*, 5625. (b) Baker, M. V.; Barnard, P. J.; Brayshaw, S. K.; Hickey, J. L.; Skelton, B. W.; White, A. H. *Dalton Trans.* **2005**, *1*, 37. (c) Frémont, P.; Scott, N. M.; Stevens, E. D.; Nolan, S. P. *Organometallics* **2005**, *24*, 2411. (d) Singh, S.; Kumar, S. S.; Jancik, V.; Roesky, H. W.; Schmidt, H. G.; Noltemeyer, M. *Eur. J. Inorg. Chem.* **2005**, *15*, 3057.
- (155) Corma, A.; Gutiérrez-Puebla, E.; Iglesias, M.; Monge, A.; Pérez-Ferreras, S.; Sánchez, F. *Adv. Synth. Catal.* **2006**, *348*, 1899.
- (156) (a) Corma, A.; González-Arellano, C.; Iglesias, M.; Sánchez, F. *Angew. Chem., Int. Ed.* **2007**, *46*, 7820. (b) Corma, A.; González-Arellano, C.; Iglesias, M.; Pérez-Ferreras, S.; Sánchez, F. *Synlett* **2007**, *11*, 1771.
- (157) Laitar, D. S.; Mueller, P.; Gray, T. G.; Sadighi, J. P. *Organometallics* **2005**, *24*, 4503.
- (158) Akana, J. A.; Bhattacharyya, K. X.; Mueller, P.; Sadighi, J. P. *J. Am. Chem. Soc.* **2007**, *129*, 7736.
- (159) (a) Fremont, P.; Stevens, E. D.; Eelman, M. D.; Fogg, D. E.; Nolan, S. P. *Organometallics* **2006**, *25*, 5824. (b) Partyka, D. V.; Esswein, A. J.; Zeller, M.; Hunter, A. D.; Gray, T. G. *Organometallics* **2007**, *26*, 3279. (c) Ricard, L.; Gagosz, F. *Organometallics* **2007**, *26*, 4704. (d) Fedorov, A.; Moret, M. E.; Chen, P. *J. Am. Chem. Soc.* **2008**, *130*, 8880.
- (160) Wang, H. M. J.; Vasam, C. S.; Tsai, T. Y. R.; Chen, S. H.; Chang, A. H. H.; Lin, I. J. B. *Organometallics* **2005**, *24*, 486.
- (161) Ruiz, J.; Perandones, B. F. *J. Am. Chem. Soc.* **2007**, *129*, 9298.
- (162) Frémont, P.; Stevens, E. D.; Fructos, M. R.; Mar Diaz-Requejo, M.; Perez, P. J.; Nolan, S. P. *Chem. Commun.* **2006**, *19*, 2045.
- (163) Amijs, C. H. M.; López-Carrillo, V.; Raducan, M.; Peñez-Galañ, P.; Ferrer, C.; Echavarrén, A. M. *J. Org. Chem.* **2008**, *73*, 7721.
- (164) (a) Baker, M. V.; Barnard, P. J.; Berners-Price, S. J.; Brayshaw, S. K.; Hickey, J. L.; Skelton, B. W.; White, A. H. *Dalton Trans.* **2006**, *30*, 3708. (b) Hickey, J. L.; Ruhayel, R. A.; Barnard, P. J.; Baker, M. V.; Berners-Price, S. J.; Filipovska, A. *J. Am. Chem. Soc.* **2008**, *130*, 12570.
- (165) (a) Horvath, U. E. I.; Bentivoglio, G.; Hummel, M.; Schottenberger, H.; Wurst, K.; Nell, M. J.; van Rensburg, C. E. J.; Cronje, S.; Raubenheimer, H. G. *New J. Chem.* **2008**, *32*, 533. (b) Catalano, V. J.; Moore, A. L. *Inorg. Chem.* **2005**, *44*, 6558. (c) Catalano, V. J.; Etogo, A. O. *J. Organomet. Chem.* **2005**, *690*, 6041.
- (166) (a) Wang, J.-W.; Song, H.-B.; Li, Q.-S.; Xu, F.-B.; Zhang, Z.-Z. *Inorg. Chim. Acta* **2005**, *358*, 3653. (b) Liu, A.; Zhang, X.; Chen, W.; Qiu, H. *Inorg. Chem. Commun.* **2008**, *11*, 1128.
- (167) Lavallo, V.; Frey, G. D.; Kousar, S.; Donnadiou, B.; Bertrand, G. *Proc. Natl. Acad. Sci. U.S.A.* **2007**, *104*, 13569.
- (168) Frey, G. D.; Dewhurst, R. D.; Kousar, S.; Donnadiou, B.; Bertrand, G. *J. Organomet. Chem.* **2008**, *693*, 1674.
- (169) Lavallo, V.; Frey, G. D.; Donnadiou, B.; Soleilhavoup, M.; Bertrand, G. *Angew. Chem., Int. Ed.* **2008**, *47*, 5224.
- (170) (a) Hashmi, A. S. K. *Chem. Rev.* **2007**, *107*, 3180. (b) Gorin, D. J.; Toste, F. D. *Nature* **2007**, *446*, 395. (c) Fürstner, A.; Davies, P. W. *Angew. Chem., Int. Ed.* **2007**, *46*, 3410. (d) Hashmi, A. S. K. *Angew. Chem., Int. Ed.* **2005**, *44*, 6990. (e) Hashmi, A. S. K. *Gold Bull.* **2003**, *36*, 3.
- (171) Urbano, J.; Hormigo, A. J.; de Frémont, P.; Nolan, S. P.; Díaz-Requejo, M. M.; Pérez, P. J. *Chem. Commun.* **2008**, 759.
- (172) Li, G.; Zhang, G.; Zhang, L. *J. Am. Chem. Soc.* **2008**, *130*, 3740.
- (173) (a) Shapiro, N. D.; Toste, F. D. *J. Am. Chem. Soc.* **2008**, *130*, 9244. (b) Porcel, S.; López-Carrillo, V.; García-Yebra, C.; Echavarrén, A. M. *Angew. Chem., Int. Ed.* **2008**, *47*, 1883. (c) Bender, C. F.; Widenhoefer, R. A. *Chem. Commun.* **2008**, 2741.
- (174) Zhang, Z.; Widenhoefer, R. A. *Org. Lett.* **2008**, *10*, 2079.
- (175) Kinder, R. E.; Zhang, Z.; Widenhoefer, R. A. *Org. Lett.* **2008**, *10*, 3157.
- (176) Zhang, G.; Huang, X.; Li, G.; Zhang, L. *J. Am. Chem. Soc.* **2008**, *130*, 1814.
- (177) Li, G.; Huang, X.; Zhang, L. *J. Am. Chem. Soc.* **2008**, *130*, 6944.
- (178) Berners-Price, S. J.; Mirabelli, C. K.; Johnson, R. K.; Mattern, M. R.; McCabe, F. L.; Faucette, L. F.; Sung, C.-M.; Mong, S.-M.; Sadler, P. J.; Crooke, S. T. *Cancer Res.* **1986**, *46*, 5486.
- (179) McKeage, M. J.; Maharaj, L.; Berners-Price, S. J. *Coord. Chem. Rev.* **2002**, *232*, 127.
- (180) McKeage, M. J.; Berners-Price, S. J.; Galetti, P.; Bowen, R. J.; Brouwer, W.; Ding, L.; Zhuang, L.; Baguley, B. C. *Cancer Chemother. Pharmacol.* **2000**, *46*, 343.
- (181) Rigobello, M. P.; Messori, L.; Marcon, G.; Cinellu, M. A.; Bragadin, M.; Folda, A.; Scutari, G.; Bindoli, A. *J. Inorg. Biochem.* **2004**, *98*, 1634.
- (182) Jellicoe, M. M.; Nichols, S. J.; Callus, B. A.; Baker, M. V.; Barnard, P. J.; Berners-Price, S. J.; Whelan, J.; Yeoh, G. C.; Filipovska, A. *Carcinogenesis* **2008**, *29*, 1124.
- (183) Raubenheimer, H. G.; Cronje, S.; van Rooyen, P. H.; Olivier, P. J.; Toerien, J. G. *Angew. Chem., Int. Ed.* **1994**, *33*, 672.
- (184) Raubenheimer, H. G.; Cronje, S.; Olivier, P. J. *J. Chem. Soc., Dalton Trans.* **1995**, 313.
- (185) Boehme, C.; Frenking, G. *Organometallics* **1998**, *17*, 5801.
- (186) Tulloch, A. A. D.; Danopoulos, A. A.; Kleinhenz, S.; Light, M. E.; Hursthouse, M. B.; Eastham, G. *Organometallics* **2001**, *20*, 2027.
- (187) Arnold, P. L.; Scarisbrick, A. C.; Blake, A. J.; Wilson, C. *Chem. Commun.* **2001**, 2340.
- (188) Fraser, P. K.; Woodward, S. *Tetrahedron Lett.* **2001**, *42*, 2747.
- (189) Pytkowicz, J.; Roland, S.; Mangeney, P. *Tetrahedron: Asymmetry* **2001**, *12*, 2087.
- (190) Jurkauskas, V.; Sadighi, J. P.; Buchwald, S. L. *Org. Lett.* **2003**, *5*, 2417.
- (191) Díez-González, S.; Nolan, S. P. *Synlett* **2007**, 2158.
- (192) Guillen, F.; Winn, C. L.; Alexakis, A. *Tetrahedron: Asymmetry* **2001**, *12*, 2083.
- (193) Alexakis, A.; Winn, C. L.; Guillen, F.; Pytkowicz, J.; Roland, S.; Mangeney, P. *Adv. Synth. Catal.* **2003**, *345*, 345.
- (194) Perry, M. C.; Burgess, K. *Tetrahedron: Asymmetry* **2003**, *14*, 951.
- (195) Seo, H.; Hirsch-Weil, D.; Abboud, K. A.; Hong, S. *J. Org. Chem.* **2008**, *73*, 1983.
- (196) Ku, R. Z.; Huang, J. C.; Cho, J. Y.; Kiang, F. M.; Reddy, K. R.; Chen, Y. C.; Lee, K. J.; Lee, J. H.; Lee, G. H.; Peng, S. M.; Liu, S. T. *Organometallics* **1999**, *18*, 2145.
- (197) Liu, S.-T.; Rajender Reddy, K. *Chem. Soc. Rev.* **1999**, *28*, 315.
- (198) Gischig, S.; Togni, A. *Organometallics* **2005**, *24*, 203.
- (199) Sigma-Aldrich is now offering a [Cu(NHC)Cl] complex (catalog no. 696307).
- (200) Díez-González, S.; Stevens, E. D.; Scott, N. M.; Petersen, J. L.; Nolan, S. P. *Chem.—Eur. J.* **2008**, *14*, 158.
- (201) Díez-González, S.; Scott, N. M.; Nolan, S. P. *Organometallics* **2006**, *25*, 2355.
- (202) Bantu, B.; Wang, D.; Wurst, K.; Buchmeiser, M. R. *Tetrahedron* **2005**, *61*, 12145.
- (203) Wan, X. J.; Xu, F. B.; Li, Q. S.; Song, H. B.; Zhang, Z. *Inorg. Chem. Commun.* **2005**, *8*, 1053.
- (204) Arnold, P. L.; Rodden, M.; Davis, K. M.; Scarisbrick, A. C.; Blake, A. J.; Wilson, C. *Chem. Commun.* **2004**, 1612.
- (205) Legault, C. Y.; Kendall, C.; Charette, A. B. *Chem. Commun.* **2005**, 3826.
- (206) Tominaga, S.; Oi, Y.; Kato, T.; An, D. K.; Okamoto, S. *Tetrahedron Lett.* **2004**, *45*, 5585.
- (207) Kaur, H.; Zinn, F. K.; Stevens, E. D.; Nolan, S. P. *Organometallics* **2004**, *23*, 1157.
- (208) Díez-González, S.; Kaur, H.; Zinn, F. K.; Stevens, E. D.; Nolan, S. P. *J. Org. Chem.* **2005**, *70*, 4784.
- (209) Okamoto, S.; Tominaga, S.; Saino, N.; Kase, K.; Shimoda, K. *J. Organomet. Chem.* **2005**, *690*, 6001.
- (210) Welle, A.; Díez-González, S.; Tinant, B.; Nolan, S. P.; Riant, O. *Org. Lett.* **2006**, *8*, 6059.
- (211) Díez-González, S.; Correa, A.; Cavallo, L.; Nolan, S. P. *Chem.—Eur. J.* **2006**, *12*, 7558.
- (212) Zheng, S.; Li, F.; Liu, J.; Xia, C. *Tetrahedron Lett.* **2007**, *48*, 5883.
- (213) Díez-González, S.; Stevens, E. D.; Nolan, S. P. *Chem. Commun.* **2008**, 4747.
- (214) Michon, C.; Ellern, A.; Angelici, R. J. *Inorg. Chim. Acta* **2006**, *359*, 4549.
- (215) Mankad, N. P.; Laitar, D. S.; Sadighi, J. P. *Organometallics* **2004**, *23*, 3369.
- (216) Deutsch, C.; Krause, N.; Lipshutz, B. H. *Chem. Rev.* **2008**, *108*, 2916.
- (217) Laitar, D. S.; Müller, P.; Sadighi, J. P. *J. Am. Chem. Soc.* **2005**, *127*, 17196.

- (218) Zhao, H.; Lin, Z.; Marder, T. B. *J. Am. Chem. Soc.* **2006**, *128*, 15637.
- (219) Bhattacharyya, K. X.; Akana, J. A.; Laitar, D. S.; Berlin, J. M.; Sadighi, J. P. *Organometallics* **2008**, *27*, 2682.
- (220) (a) Laitar, D. S.; Tsui, E. Y.; Sadighi, J. P. *Organometallics* **2006**, *25*, 2405. For discussions on related catalytic reaction and mechanism, see: (b) Lillo, V.; Fructos, M. R.; Ramírez, J.; Braga, A. A. C.; Maseras, F.; Díaz-Requejo, M. M.; Pérez, P. J.; Fernández, E. *Chem.—Eur. J.* **2007**, *13*, 2614.
- (221) Dang, L.; Zhao, H. T.; Lin, Z. Y.; Marder, T. B. *Organometallics* **2008**, *27*, 1178.
- (222) Dang, L.; Zhao, H.; Lin, Z.; Marder, T. B. *Organometallics* **2007**, *26*, 2824.
- (223) Laitar, D. S.; Tsui, E. Y.; Sadighi, J. P. *J. Am. Chem. Soc.* **2006**, *128*, 11036.
- (224) Zhao, H.; Dang, L.; Marder, T. B.; Lin, Z. *J. Am. Chem. Soc.* **2008**, *130*, 5586.
- (225) Dubinina, G. G.; Furutachi, H.; Vicic, D. A. *J. Am. Chem. Soc.* **2008**, *130*, 8600.
- (226) Mankad, N. P.; Gray, T. G.; Laitar, D. S.; Sadighi, J. P. *Organometallics* **2004**, *23*, 1191.
- (227) Goj, L. A.; Blue, E. D.; Delp, S. A.; Gunnoe, T. B.; Cundari, T. R.; Petersen, J. L. *Organometallics* **2006**, *25*, 4097.
- (228) Goj, L. A.; Blue, E. D.; Munro-Leighton, C.; Gunnoe, T. B.; Petersen, J. L. *Inorg. Chem.* **2005**, *44*, 8647.
- (229) Delp, S. A.; Munro-Leighton, C.; Goj, L. A.; Ramírez, M. A.; Gunnoe, T. B.; Petersen, J. L.; Boyle, P. D. *Inorg. Chem.* **2007**, *46*, 2365.
- (230) Nolte, C.; Mayer, P.; Straub, B. F. *Angew. Chem., Int. Ed.* **2007**, *46*, 2101.
- (231) Goj, L. A.; Blue, E. D.; Delp, S. A.; Gunnoe, T. B.; Cundari, T. R.; Pierpont, A. W.; Petersen, J. L.; Boyle, P. D. *Inorg. Chem.* **2006**, *45*, 9032.
- (232) Ren, H.; Zhao, X.; Xu, S.; Song, H.; Wang, B. *J. Organomet. Chem.* **2006**, *691*, 4109.
- (233) Niemeyer, M. Z. *Anorg. Allg. Chem.* **2003**, *629*, 1535.
- (234) York, J. T.; Young, V. G., Jr.; Tolman, W. B. *Inorg. Chem.* **2006**, *45*, 4191.
- (235) Hsu, S. H.; Li, C. Y.; Chiu, Y. W.; Chiu, M. C.; Lien, Y. L.; Kuo, P. C.; Lee, H. M.; Huang, J. H.; Cheng, C. P. *J. Organomet. Chem.* **2007**, *692*, 5421.
- (236) Hu, X.; Castro-Rodríguez, I.; Meyer, K. *J. Am. Chem. Soc.* **2003**, *125*, 12237.
- (237) Yun, J.; Kim, D.; Yun, H. *Chem. Commun.* **2005**, 5181.
- (238) Knishevitsky, A. V.; Korotkikh, N. I.; Cowley, A. H.; Moore, J. A.; Pekhtereva, T. M.; Shvaika, O. P.; Reeske, G. *J. Organomet. Chem.* **2008**, *693*, 1405.
- (239) Nonnenmacher, M.; Kunz, D.; Rominger, F. *Organometallics* **2008**, *27*, 1561.
- (240) Danopoulos, A. A.; Cole, P.; Downing, S. P.; Pugh, D. *J. Organomet. Chem.* **2008**, *693*, 3369.
- (241) Schneider, N.; César, V.; Bellemin-Lapponaz, S.; Gade, L. H. *J. Organomet. Chem.* **2005**, *690*, 5556.
- (242) Hu, X.; Castro-Rodríguez, I.; Meyer, K. *Organometallics* **2003**, *22*, 3016.
- (243) Albrecht, M. *Chem. Commun.* **2008**, 3601.
- (244) Hu, X.; Castro-Rodríguez, I.; Olsen, K.; Meyer, K. *Organometallics* **2004**, *23*, 755.
- (245) Larsen, A. O.; Leu, W.; Nieto Oberhuber, C.; Campbell, J. E.; Hoveyda, A. H. *J. Am. Chem. Soc.* **2004**, *126*, 11130.
- (246) Van Veldhuizen, J. J.; Campbell, J. E.; Giudici, R. E.; Hoveyda, A. H. *J. Am. Chem. Soc.* **2005**, *127*, 6877.
- (247) Díez-González, S.; Nolan, S. P. *Acc. Chem. Res.* **2008**, *41*, 349.
- (248) Falciola, C. A.; Alexakis, A. *Eur. J. Org. Chem.* **2008**, 3765.
- (249) Gunnoe, T. B. *Eur. J. Inorg. Chem.* **2007**, 1185.
- (250) Beenen, M. A.; An, C.; Ellman, J. A. *J. Am. Chem. Soc.* **2008**, *130*, 6910.
- (251) Xu, Q.; Appella, D. H. *Org. Lett.* **2008**, *10*, 1497.
- (252) Ohishi, T.; Nishiura, M.; Hou, Z. *Angew. Chem., Int. Ed.* **2008**, *47*, 5792.
- (253) Matsumoto, Y.; Yamada, K.; Tomioka, K. *J. Org. Chem.* **2008**, *73*, 4578.
- (254) Tubaro, C.; Biffis, A.; Scattolin, E.; Basato, M. *Tetrahedron* **2008**, *64*, 4187.
- (255) Beier, M. J.; Knolle, W.; Prager-Duschke, A.; Buchmeiser, M. R. *Macromol. Rapid Commun.* **2008**, *29*, 904.
- (256) Wang, M.; Li, P.; Wang, L. *Eur. J. Org. Chem.* **2008**, 2255.
- (257) (a) Cheung, K. L.; Yip, S. K.; Yam, V. W. W. *J. Organomet. Chem.* **2004**, *689*, 4451. (b) Yam, V. W. W.; Cheng, E. C. C. *Chem. Soc. Rev.* **2008**, *37*, 1806.
- (258) Omary, M. A.; Mohamed, A. A.; Rawashdeh-Omary, M. A.; Fackler, J. P., Jr. *Coord. Chem. Rev.* **2005**, *249*, 1372.
- (259) Liu, Q.-X.; Xu, F.-B.; Li, Q.-S.; Zeng, X.-S.; Leng, X.-B.; Chou, Y. L.; Zhang, Z.-Z. *Organometallics* **2003**, *22*, 309.
- (260) Barnard, P. J.; Baker, M. V.; Berners-Price, S. J.; Skelton, B. W.; White, A. H. *Dalton Trans.* **2004**, 1038.
- (261) Catalano, V. J.; Malwitz, M. A. *Inorg. Chem.* **2003**, *42*, 5483.

CR8005153